

Civil Action 2020-CP-10-5405

MAGNUS E SHIER III

PLAINTIFF

VS

DANNY D. HENRIKSEN

Defendant.

Letter

RECEIVED

SEP 22 2021

SC Court of Appeals

Documents for case

Danny D. Henriksen

3/2/21

FILED

2021 MAR -2 PM 2:14

CLERK OF COURT

BY



EDGEWATER KITCHENS COMPLAINT

Contractor did not complete work on cabinets in a timely manner.

Did not tile the backsplash per drawings

Did not install cabinet glass doors on the north wall.

Did not finish the corner pantry installation.

Did not finish the Island trim or install cabinet door.

Contractor did extort payments to install the final cabinet.

Edgewater kitchens entered into a contract, to complete my kitchen on 9/26/19 with the exceptions of appliances, electrical, and plumbing. The project according to them would take approximately four weeks. They were to install the cabinets, Island, corner pantry, complete the backsplash, install the counter tops per the agreed drawings and artistic designs.

During the negotiations of the contract, we discussed in length what was to be done. We discussed the tiling of backsplash with subway tile and the corner pantry. The cabinet glass doors were the last addition to the contract.

They had told me were to go to look at designs of tile and countertops. The initial price of the work was 25,500.00. When the backsplash was added the price was 29119.84. The cabinet glass windows on the north wall was, the last item which raised the price to 31,509.84.

Into the renovations on the sixth week, problems with working relations started when the contractor presented on 1/17/20 addendum prices for so called additional work, without any prior approval. The figures were wrote on a piece of cardboard, \$1000.00 for administration fees for counter top installation, \$1000.00 for sheetrock work, \$1100.00 for floor molding. I told him that we had discussed that before we entered into the contract and it was included. That is when he wanted to see the contract I was talking about.

The Contractor basically held the kitchen unusable for 8 weeks. He used saws, planners, and sanders in the house without catch bags attached. Although it is

sometimes necessary to use these tools inside the house, most of the time it is not. I asked that he not use the saw inside the house unless necessary after the counter tops were installed, he did so anyway. He reduced his hours from 30 per week, to about 20 prolonging the job while continuing to create a mess inside the house and creating a hazardous environment for the occupants of the house. After 8 weeks, on January 30th, my son and I removed his tools from the kitchen and notified him to pick them up.

On February 1st meeting at Edgewater Kitchens office. Paid \$2850 to get last or extortion cabinet installed. On 2/3/20202 he started installing the last cabinet.

Please see attachments

1. Contract signed by Magnus Shier
2. Financial figures for complaint.
3. Time line for contract.
4. Text messages for time of contract.
5. Pictures of kitchen, living room and bedroom during remodeling of kitchen.
6. 1-ARTISTIC DRAWING + ORIGINAL DESIGNS WITH GRAPHIC models.
7. PAYMENTS MADE TO EDGEWATER KITCHENS.
8. INVOICES FROM EDGEWATER KITCHENS
9. COUNTER TOP SQ. FT. CALCULATIONS INSTALLED

Contract for Kitchen remodel
322 Cabell St, Charleston S.C.

- (1. Remove existing cabinets.) Habitat
2. Build corner Walled pantry per Drawings.
 3. Install new cabinets and island per design Layout.
Placement of island to be determined in field.
 4. Install crown molding and lower molding, and finish cabinets.
 5. Install counter tops, backsplash, and mount sinks.
 6. Install floor moldings as needed.
 7. Contractor to provide labor and material as needed.
 8. Owner will provide, sinks, plumbing fixtures, mixing valves, cabinet hardware, electrical wiring, receptacles, and appliances. No plumbing, electrical or HVAC work is included in this contract.

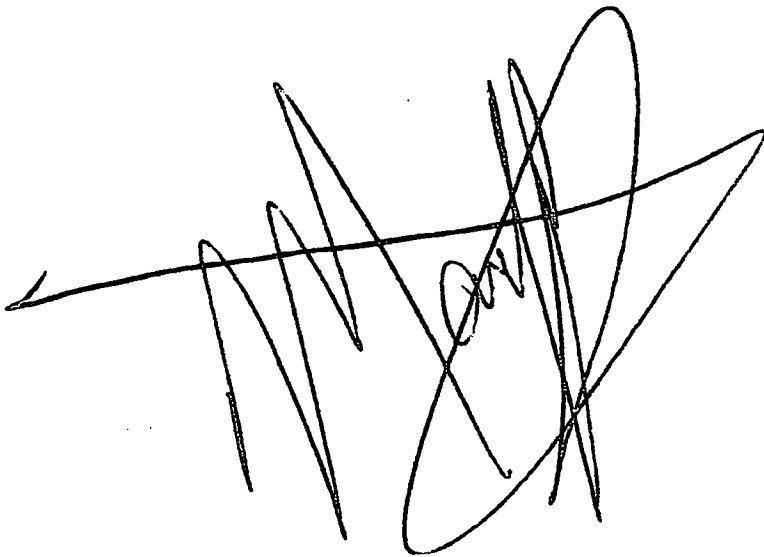
A large, stylized handwritten signature in black ink, consisting of several overlapping loops and sharp points, positioned at the bottom of the page.

Financial Figures for Complaint

Cabinet window Doors	\$2390
Backsplash Tile	\$2272
Finish Trim on Island and garbage cab. Door	\$2000
Preparation and Filing fees	\$0600
	<hr/>
Total	\$7262

Time Line 322 Cabell Kitchen

- 08/20/19 Paid \$300.00 for initial consultation and work scope verification. This fee was to be deducted from contract price if awarded.
- 09/26/19 Entered into contract Paid \$19,119.84 was told that kitchen would be complete in four weeks, except for appliances, electrical, and plumbing.
- 12/02/19 Work started, completed tear out in one day. Project to be 4 to 5 weeks.
- 12/27/19 Payment of \$6,657.00 noticed work was going slow.
- 01/07/20 Moved appliance delivery from 01/13/20 to 01/27/20.
- 01/17/20 Without any prior consent, presented an invoice for additional work, for sheetrock work, administrative fee, and floor moldings amount of \$3100.00. I informed him that the work was covered under the original contract.
- 01/20/20 Argument over what was covered under the intial contract. He said the backsplash tile work was not covered under contract.
- 01/22/20 Moved appliance delivery from 01/27/20 to 02/10/20.
- 01/23/20 Counter tops were installed by Palmetto surfacing and sinks were installed they asked if I wanted the four inch counter top backing, I said yes. Magnus said he needed another payment.
- 01/24/20 Paid Magnus \$1733.00, he said he needed more than that, and he wanted to see the contract I was talking about. He followed me to my dad's house on 2222 Longview Court, and showed him the contract which he had signed. I knew at this time I would have to take him to court, Kitchen still progressing very slow and late.

04/29/20

Pat O'Neil called again asking Magnus and I have a meeting. I told her I was not interested in having a meeting.

05/15/20

Pat O'Neil called and said I could have the cabinet door.

- 01/28/20 Another argument in the meeting, Magnus wanting more money. No work performed. Palmetto Surfacing came and installed last piece of counter top backing behind stove.
- 01/29/20 Worked 2 hours. Called and asked when the last cabinet would be installed he said whenever he got paid.
- 01/30/20 Jacob and myself moved all of Magnus tools and equipment out of the house and started cleaning up.
- 02/01/20 Meeting at Edgewater kitchens office, told Magnus there would be no more using saw inside the house, and he had one week to finish the job. Paid \$2850 to get last or extortion cabinet installed.
- 02/03/20 Installed the extortion cabinet in the afternoon.
- 02/04/20 Installed bottom trim on extortion cabinet. Informed me that the trash can pull out drawer would not be shipped until February 28.
- 02/05/20 No show
- 02/06/20 Installed trim around window and floor molding on closet.
- 02/07/20 Met Magnus and Pat O'Neil house told Pat to bring her camera if she wanted to take pictures of their work. Met at 3 PM Paid \$1000. Island trim not finished, door on garbage cabinet not installed, Pantry closet not finished, glass doors on cabinet not installed, and backsplash not tiled.
- 04/16/20 Pat O'Neil called and asked if Magnus could come and finish the job. I told her I would have to contact my sons. My sons and I decided it would be better not to let him return to finish work.
- 04/22/20 Called Magnus Shier asked if I could have cabinet door to install on the garbage cabinet, he said I still owed him \$500.00 on the contract and I could have the door once I paid him.

Conversation with Magnus Shier

Message received from Magnus Shier 12/2/2019 8:52:31 AM

MS

Sorry, I can't talk right now.

Message sent 12/2/2019 9:03:15 AM

K

12/5/2019

Message received from Magnus Shier 12/5/2019 9:36:52 AM

MS

Be there at 10:00

Message sent 12/5/2019 9:47:22 AM

K

12/6/2019

Message received from Magnus Shier 12/6/2019 9:03:04 AM

MS

11:30 or so

Message sent 12/6/2019 9:23:55 AM

Ok

12/7/2019

Message received from Magnus Shier 12/7/2019 9:55:01 AM

MS

See you Monday AM

Message sent 12/7/2019 9:55:47 AM

K

12/9/2019

MS

Message received from Magnus Shier 12/9/2019 9:49:23 AM

Be there around lunchtime or after

MS

Message received from Magnus Shier 12/9/2019 9:50:40 AM

Sorry, I can't talk right now.

12/10 2019

MS

Message received from Magnus Shier 12/10/2019 9:38:59 AM

11:00

Message sent 12/10/2019 9:51:44 AM

Your list
2 square feet flooring
Cabinets.

MS

Message received from Magnus Shier 12/10/2019 9:52:47 AM

Ok

MS

Message received from Magnus Shier 12/10/2019 3:37:07 PM

Get rid of him

12/11 2019

MS

Message received from Magnus Shier 12/11/2019 9:57:50 AM

On the way

12/12 2019

MS

Message received from Magnus Shier 12/12/2019 10:27:01 AM

On the way

12/13 2019

MS

Message received from Magnus Shier 12/13/2019 9:38:54 AM

On the w

Message received from Magnus Shier 12/13/2019 11:18:09 AM

MS

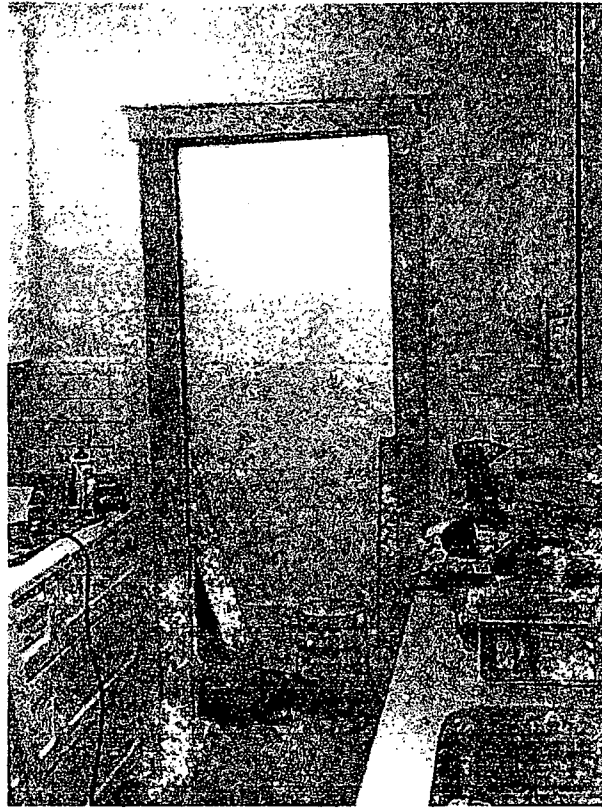

12/15 2019

Message sent 12/15/2019 2:48:21 PM

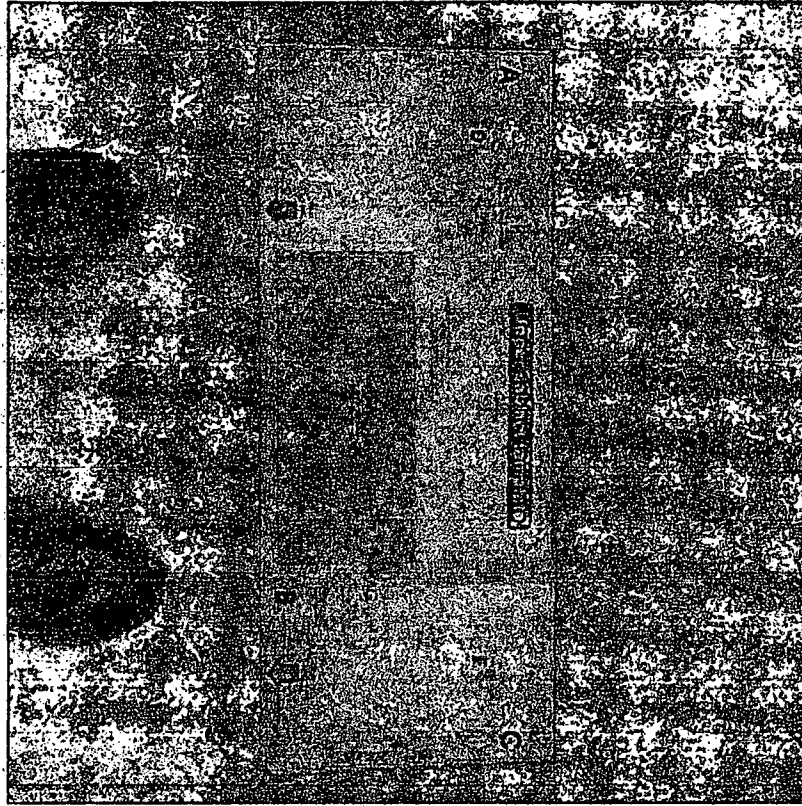

Microwave layout details.

12/18 2019

Message received from Magnus Shier 12/18/2019 2:28:39 PM

MS

230 with materials for closet

12/19 2019

Message received from Magnus Shier 12/19/2019 12:06:24 PM

MS

About 11:30

12/23 2019

Message received from Magnus Shier 12/23/2019 3:41:33 PM

MS



Message received from Magnus Shier 12/23/2019 4:01:58 PM

MS

Broom fixed door locked

12/24 2019

Message received from Magnus Shier 12/24/2019 2:03:05 PM

MS

Merry Christmas see you Thursday AM

Message sent 12/24/2019 2:34:21 PM

Merry Christmas to you and Pat!

12/28 2019

Message received from Magnus Shier 12/28/2019 12:25:24 PM

MS

Not going to get there today

Message sent 12/28/2019 1:27:19 PM

K

Message received from Magnus Shier 1/8/2020 12:48:20 PM

MS

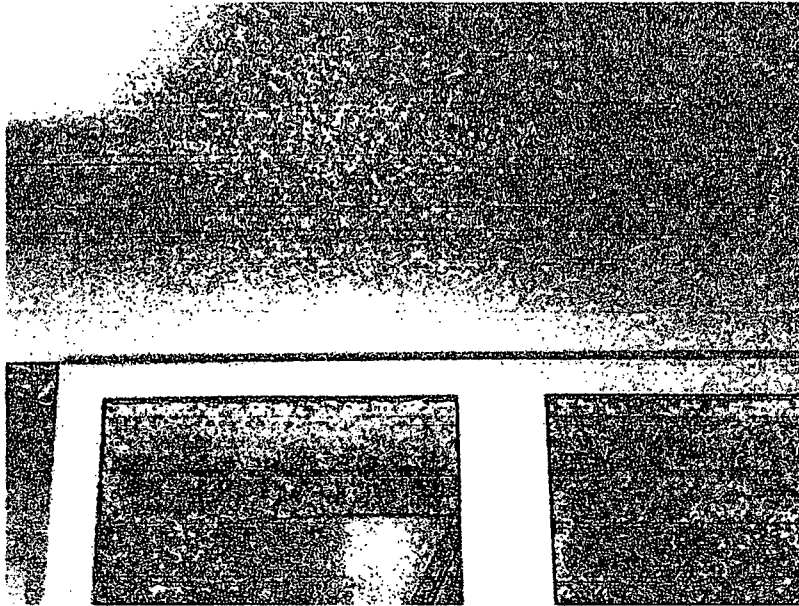

Message received from Magnus Shier 1/8/2020 1:46:58 PM

MS

Health care Rossann Santo 8434780689

Message sent 1/8/2020 2:17:43 PM

TU

1/9 2020

Message received from Magnus Shier 1/8/2020 9:06:26 PM

MS

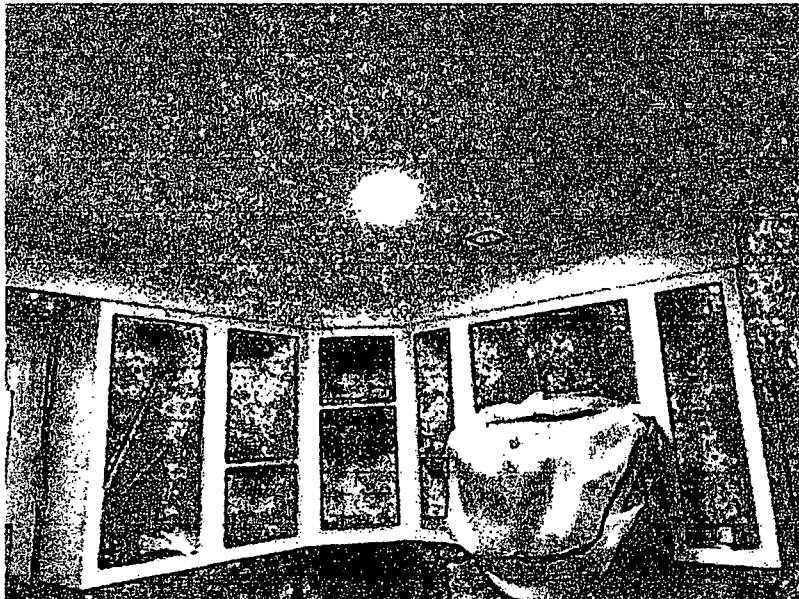

1/15/2020

Message received from Magnus Shier 1/15/2020 3:26:17 PM

MS

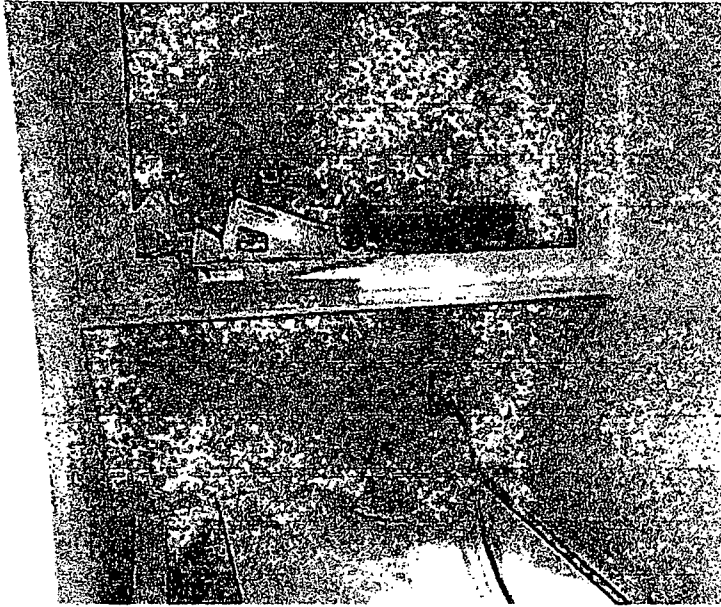

1/16/2020

MS

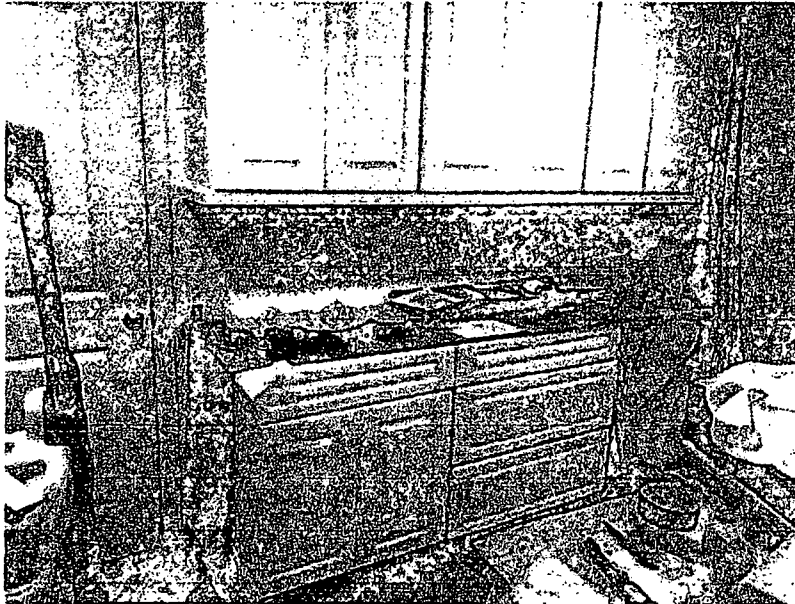
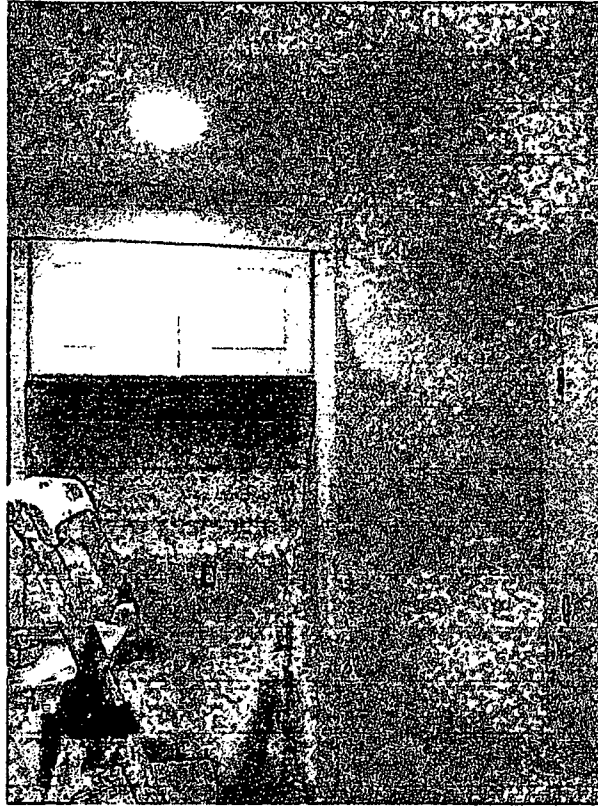

Message received from Magnus Shier 1/16/2020 6:25:51 PM

MS

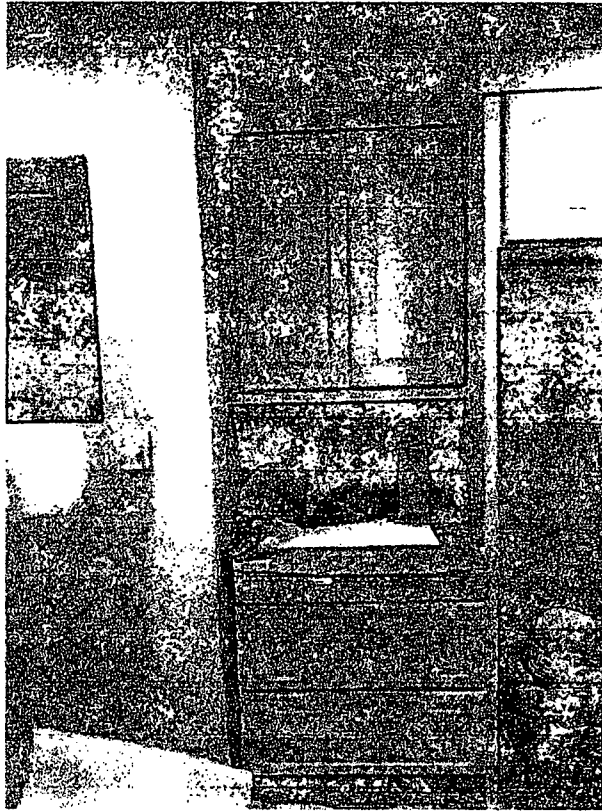
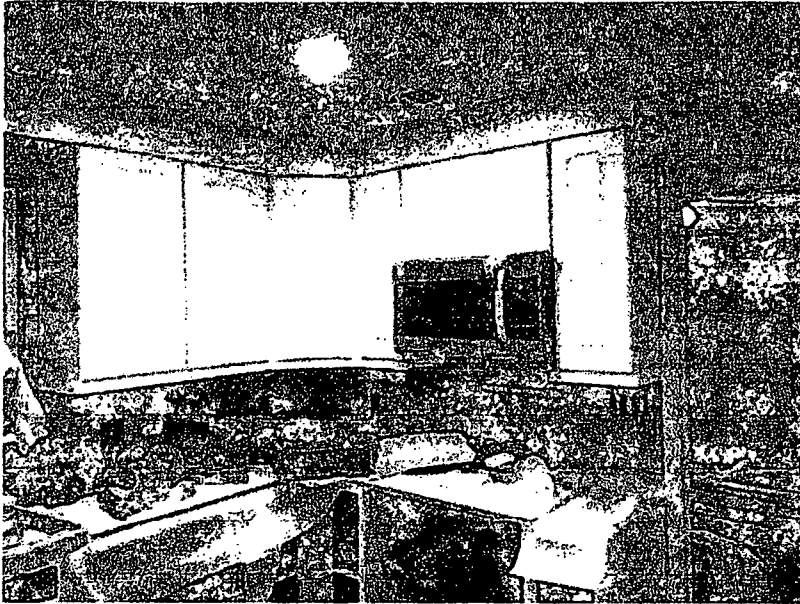

1/17/2020

Message received from Magnus Shier 1/23/2020 9:10:30 AM

MS

On the way

Message received from Magnus Shier 1/23/2020 2:09:18 PM

MS



Message sent 1/23/2020 2:16:39 PM

6-3/8" will be fine

1/26/2020

Message received from Magnus Shier 1/26/2020 12:35:03 PM

MS

Going to see sick aunt be there AM tomorrow

1/29/2020

Message received from Magnus Shier 1/28/2020 8:22:15 PM

MS

Meeting in morning

Message sent 1/28/2020 8:53:39 PM

K

Message received from Magnus Shier 1/17/2020 5:57:15 PM

MS



1/19/2020

Message received from Magnus Shier 1/18/2020 9:23:01 PM

MS

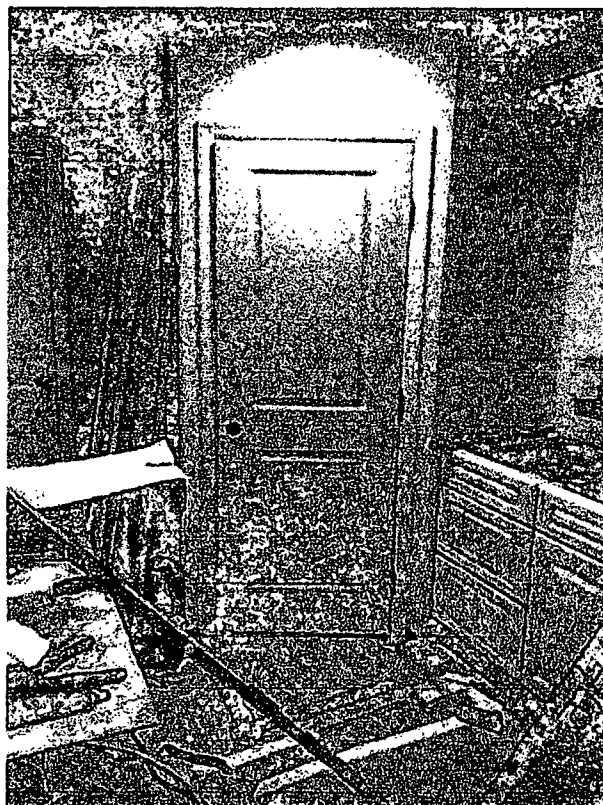

Message sent 1/19/2020 2:20:36 PM

Please install a steel shelving system of double channel hangers in the pantry. With 5 shelves at 16 inches on centers.

Message sent 1/29/2020 8:26:13 AM

Is the other base cabinet been delivered ?

Message received from Magnus Shier 1/29/2020 11:24:52 AM

MS

Yes

Message sent 1/29/2020 11:36:23 AM

Good.

Message received from Magnus Shier 1/29/2020 5:01:13 PM

MS

Pulls for large drawer centers right

Message sent 1/29/2020 5:03:12 PM

Yes

1/30/2020

Message sent 1/30/2020 11:47:29 AM

Pick up your tools today, they are on the carport.

2/3/2020

Message received from Magnus Shier 2/3/2020 12:38:22 PM

MS

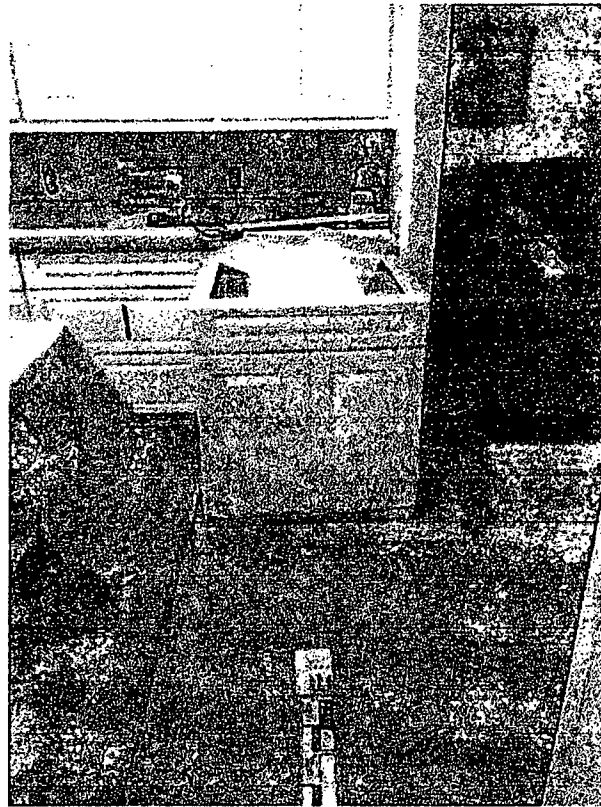

MS



MS

Message received from Magnus Shier 2/4/2020 10:41:27 AM

Trash can pullout door ships February 28

Message sent 2/4/2020 10:52:03 AM

K, TU

MS

Message received from Magnus Shier 2/4/2020 11:32:19 AM

Punch list

2/6 2020

MS

Message received from Magnus Shier 2/6/2020 1:45:26 PM

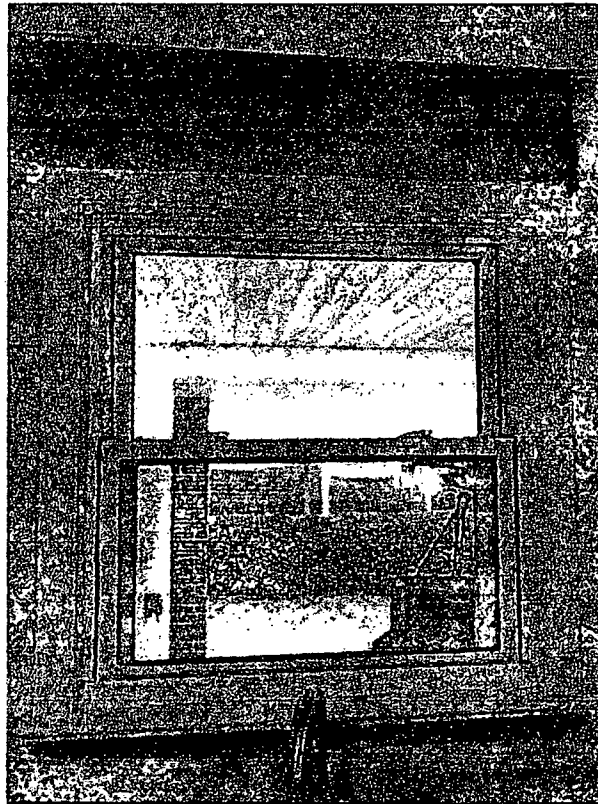

2/7 2020

MS

Message received from Magnus Shier 2/7/2020 9:04:42 AM

Money Today what time can we meet at your house

Message sent 2/7/2020 9:10:53 AM

3 Pm at Cabell street, tell Pat to bring her camera if she wants to take pictures.

Message received from Magnus Shier 2/7/2020 9:26:44 AM

MS

Ok

Message received from Magnus Shier 2/7/2020 4:57:49 PM

MS

When I come back I will put formula shins on door hinges

3/25/2020

Message received from Magnus Shier 3/25/2020 1:31:36 PM

MS

Next week by Friday will finish

Message received from Pat Oniel Edgewater kitchen 9/11/2019 2:14:25 PM

PK

Magnus is double checking information. Talk to you soon

9/12/2019

Message received from Pat Oniel Edgewater kitchen 9/12/2019 3:16:03 PM

PK



Message received from Pat Oniel Edgewater kitchen 9/12/2019 3:16:08 PM

PK

10/7/2019

Message received from Pat Oniel Edgewater kitchen 10/7/2019 2:00:12 PM

PK

Hi Dan, Magnus said he would take care of cabinets for you. Sorry called you by mistake

10/9/2019

4/16/2020

Message sent 4/16/2020 6:25:02 PM

Pat, if I could come by and pick up the door and trim kit, I can finish the island. My son's are not comfortable with Magnus coming back into the house.

Message received from Pat Oniel Edgewater kitchen 4/16/2020 6:26:24 PM

PK

I will talk to Magnus and get back to you.

Message sent 4/16/2020 6:27:14 PM

They do not want to clean up after him again.

Message received from Pat Oniel Edgewater kitchen 4/16/2020 6:28:07 PM

PK

I will tell him that.

4/21/2020

Message sent 4/21/2020 12:56:55 PM

Pat,
When would be a good time for me to come buy the office and pick up the door and remaining trim for the island?

Message received from Pat Oniel Edgewater kitchen 4/21/2020 12:59:30 PM

PK

Magnus was suppose to call you, I will remind him.

Message received from Pat Oniel Edgewater kitchen 4/21/2020 1:03:56 PM

PK

He said to call him in the morning. 843 364 3700

Message sent 4/21/2020 1:44:23 PM

K

Message received from Pat Oniel Edgewater kitchen 1/17/2020 6:00:47 PM

PK

Message received from Pat Oniel Edgewater kitchen 1/17/2020 6:01:05 PM

PK

Time to partym

2/4 2020

Message received from Pat Oniel Edgewater kitchen 2/4/2020 10:32:51 AM

PK

We received order acknowledgement from cabinet people. They will ship island door on Feb. 28

Message sent 2/4/2020 10:34:30 AM

K

Message sent 2/4/2020 10:34:35 AM

TU

2/6 2020

Message received from Pat Oniel Edgewater kitchen 2/6/2020 4:24:06 PM

PK

Looks Great

Message received from Pat Oniel Edgewater kitchen 10/8/2019 9:46:46 PM

PK

11/25/2019

Message received from Pat Oniel Edgewater kitchen 11/25/2019 2:40:28 PM

PK

Sorry I called you by mistake. Hope all is going well with you and family.
Happy Thanksgiving to all. Patt O'Neil Edgewater Kitchens

1/17/2020

Message received from Pat Oniel Edgewater kitchen 1/17/2020 6:00:22 PM

PK

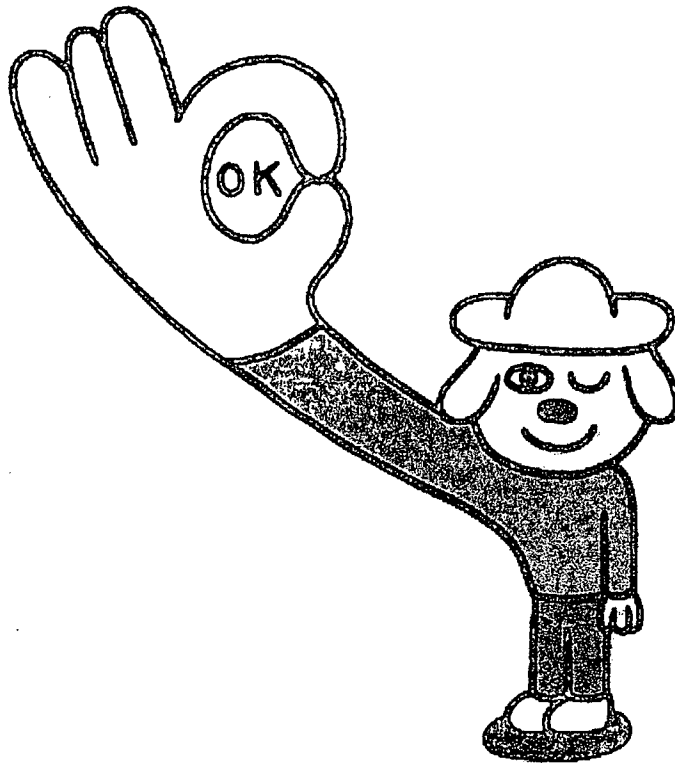

Message received from Pat Oniel Edgewater kitchen 1/17/2020 6:00:24 PM

PK

Looks good

A

Bedroom

1/2/20

ATTACH # 5

A

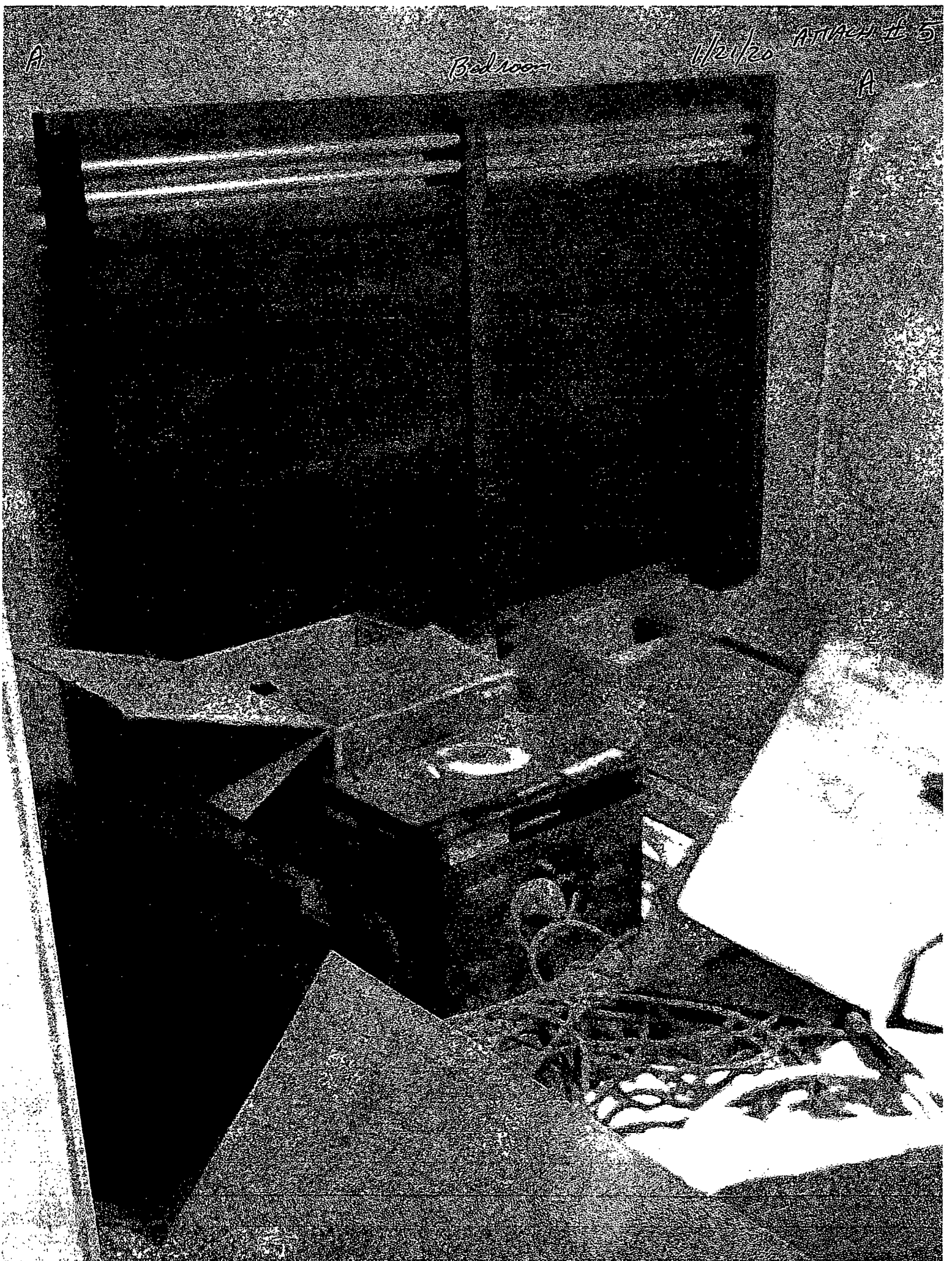

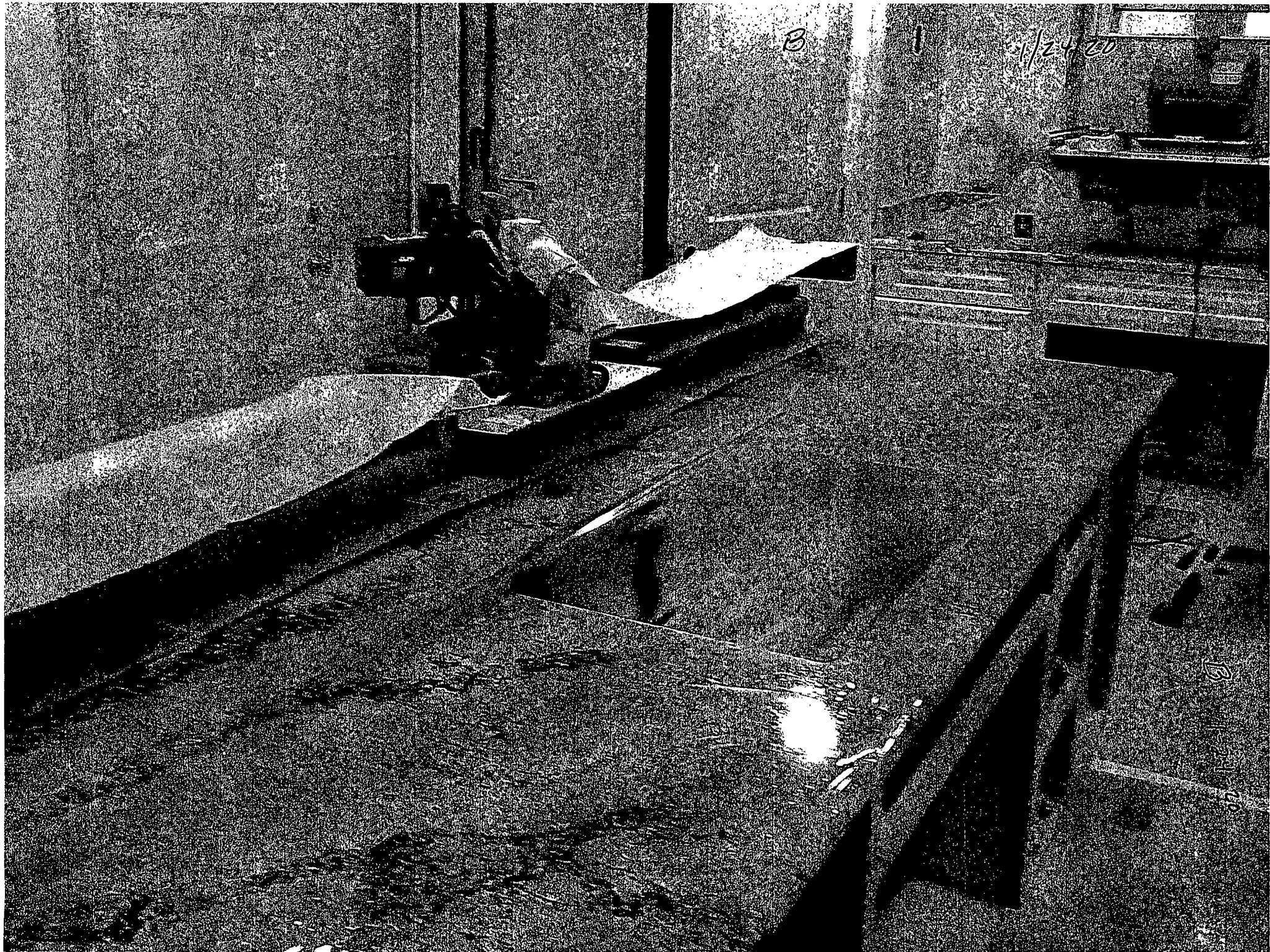

1/26/20

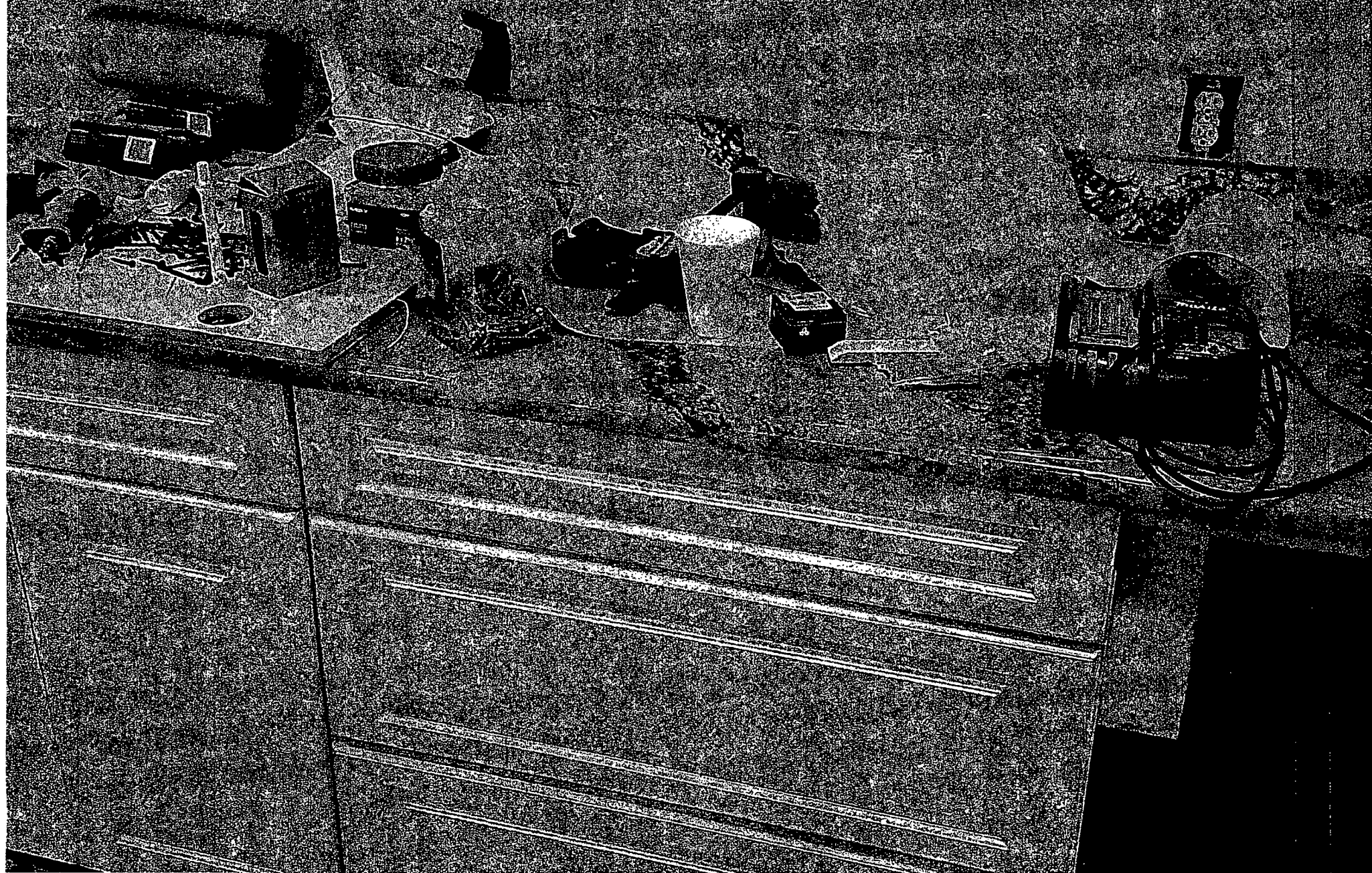

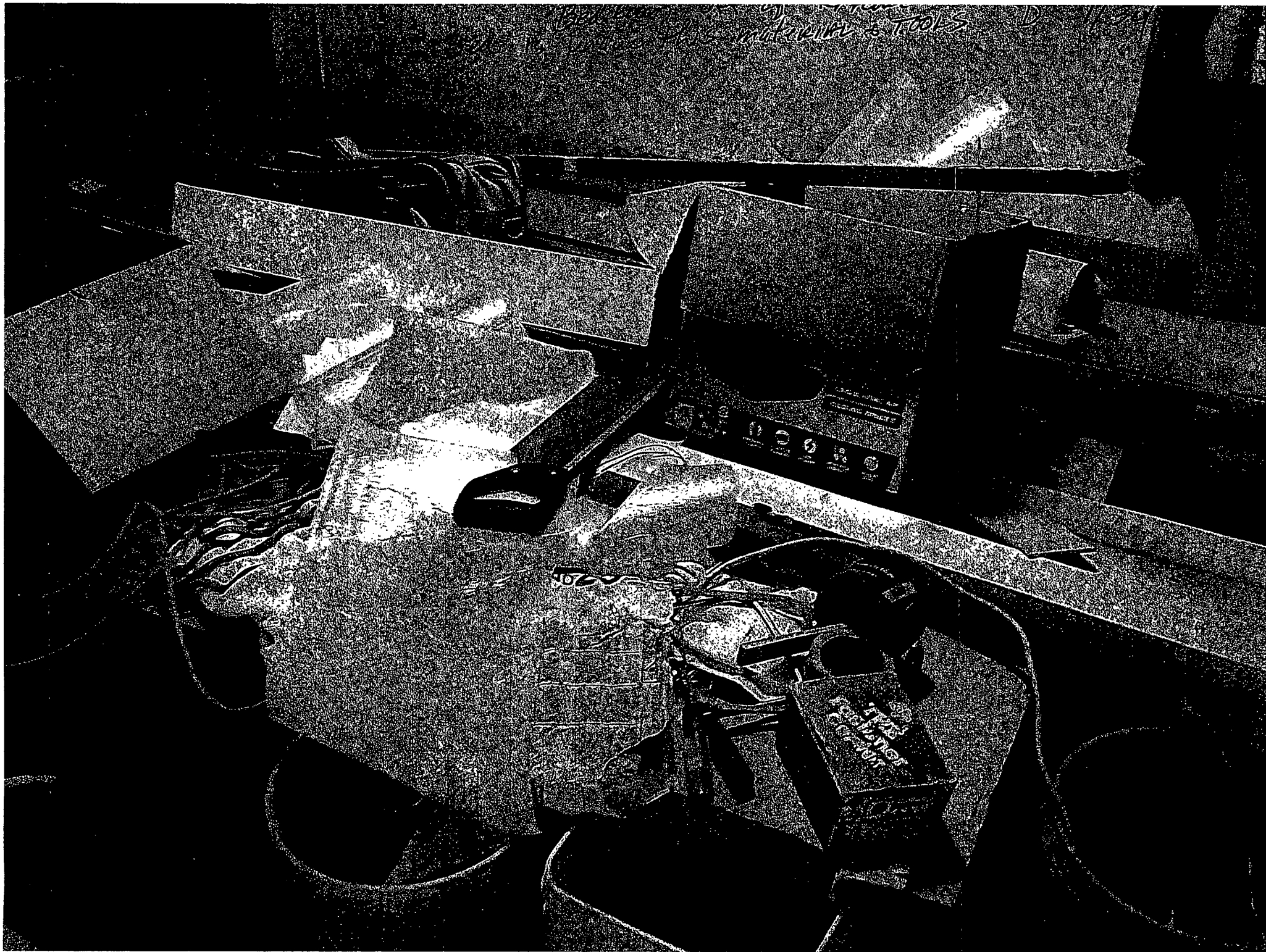



IND

POWER

TRIM
SERIES

0.21

00105

11/30/20



11/30/20

1/30/2020



front edge of paper
to back of door.

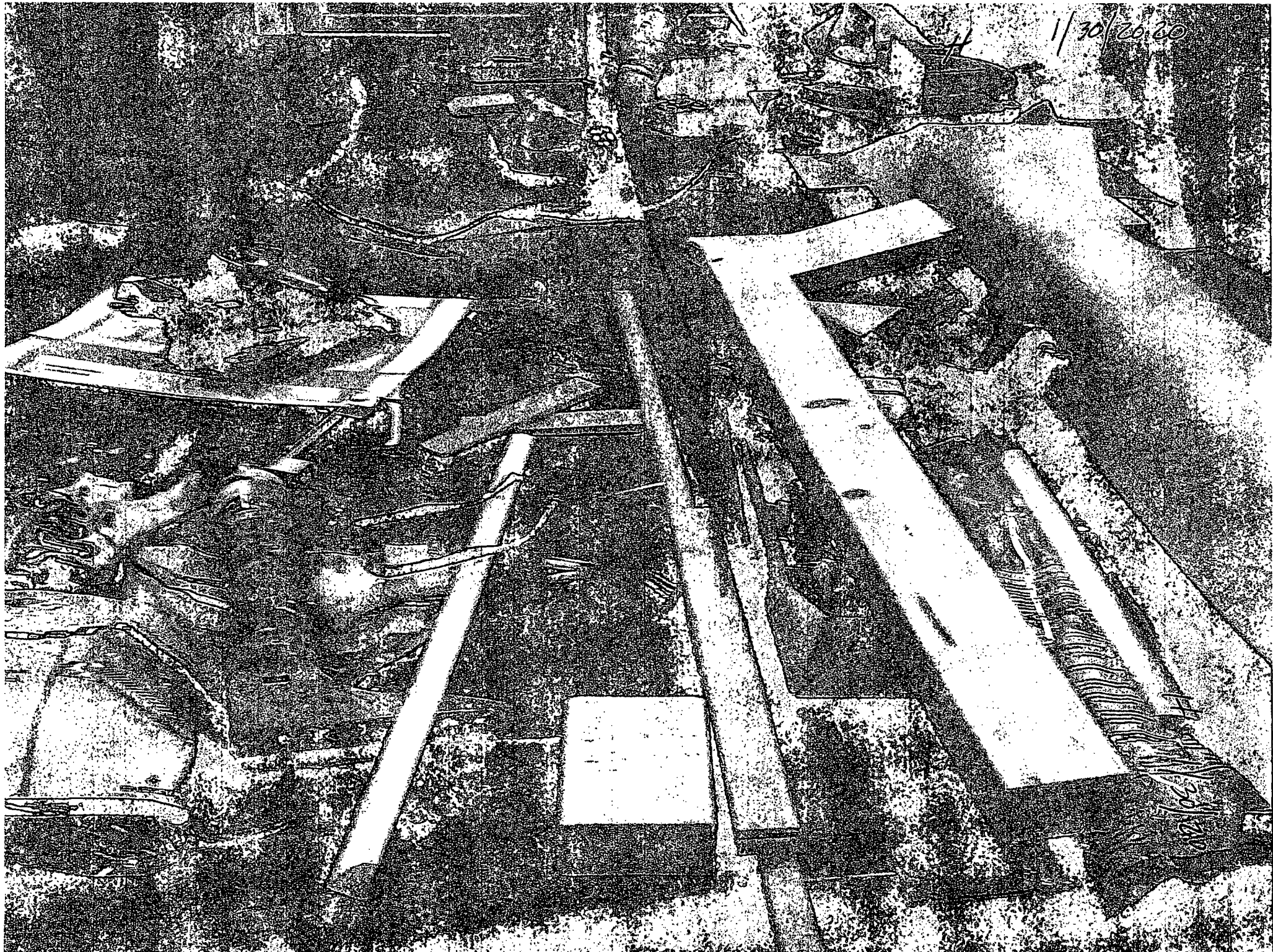

1/30/2020

1/30/2020

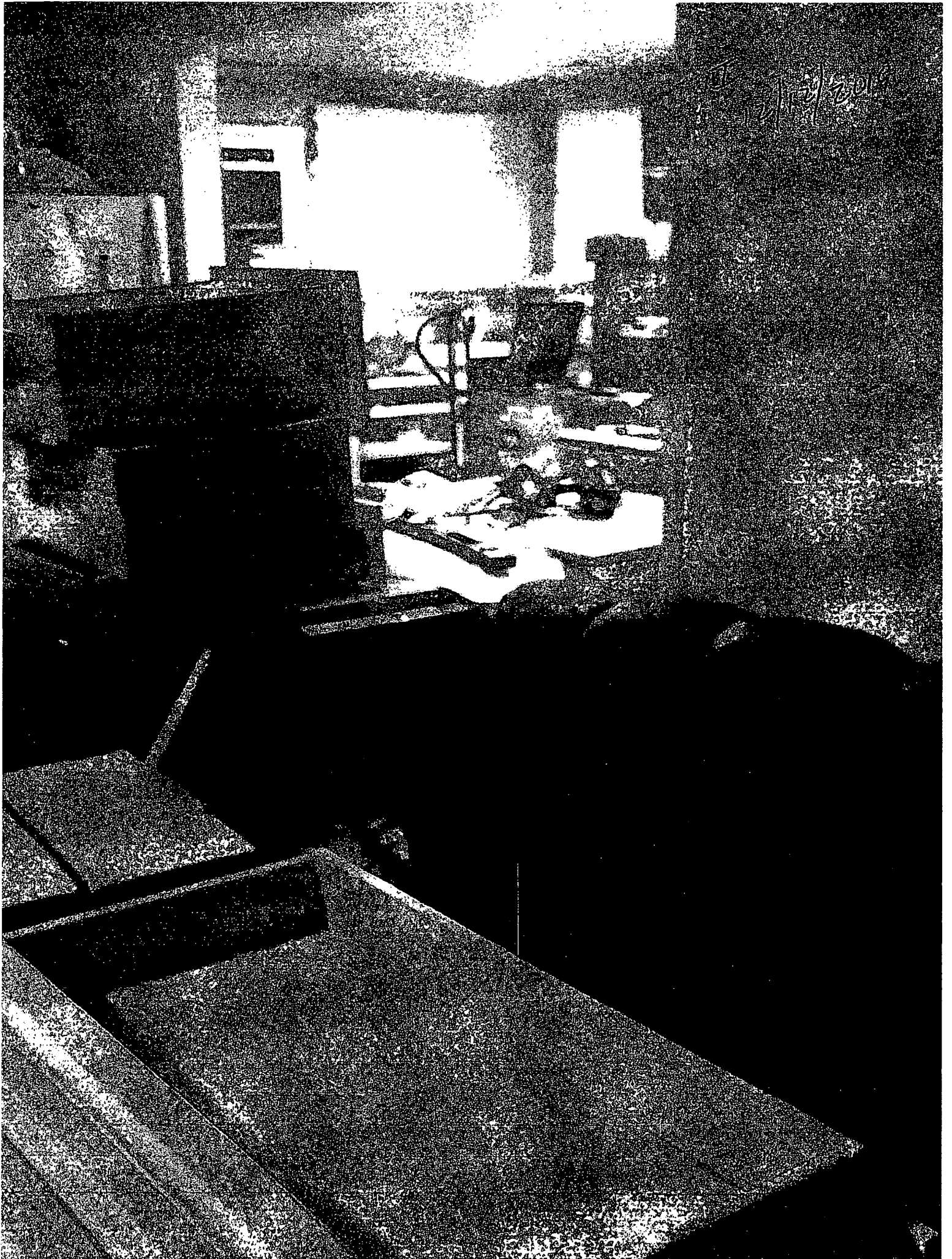

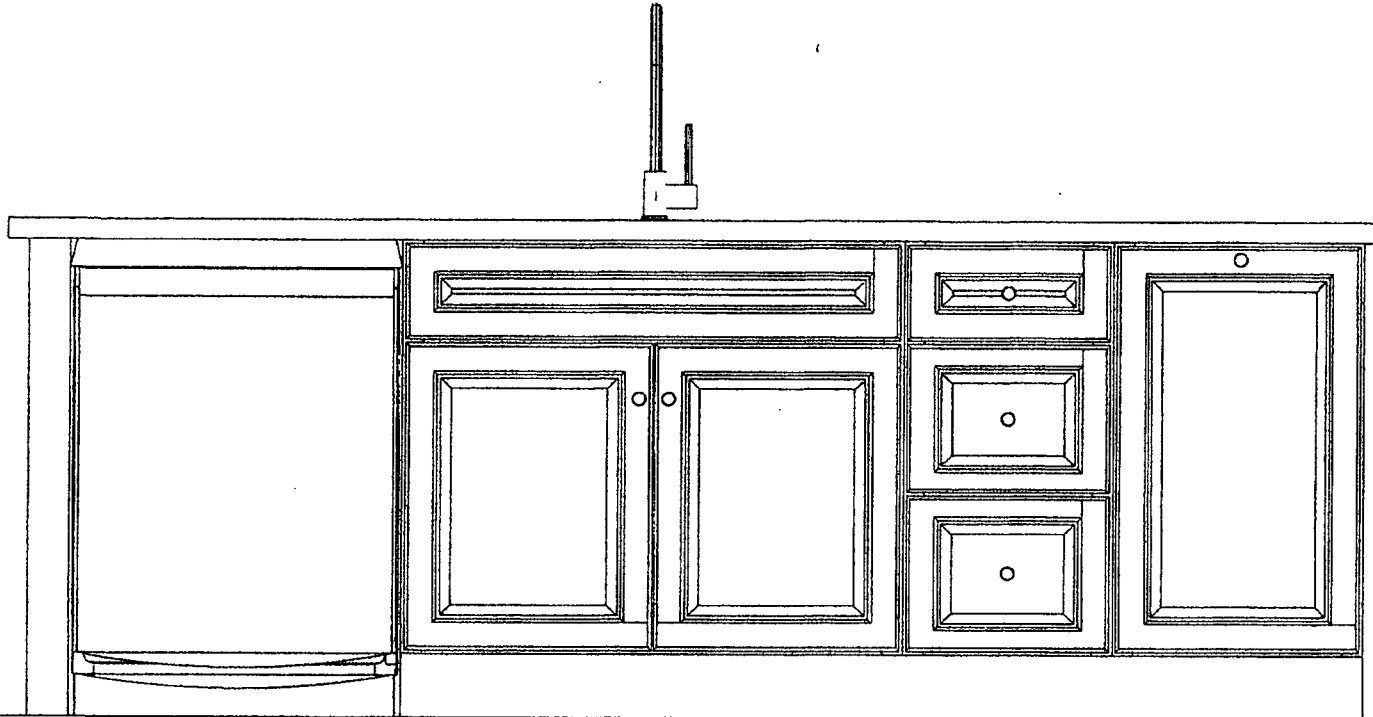

Note: This drawing is an artistic interpretation of the general appearance of the design. It is not meant to be an exact rendition.

2020

Designed: 9/11/2019
Printed: 9/11/2019

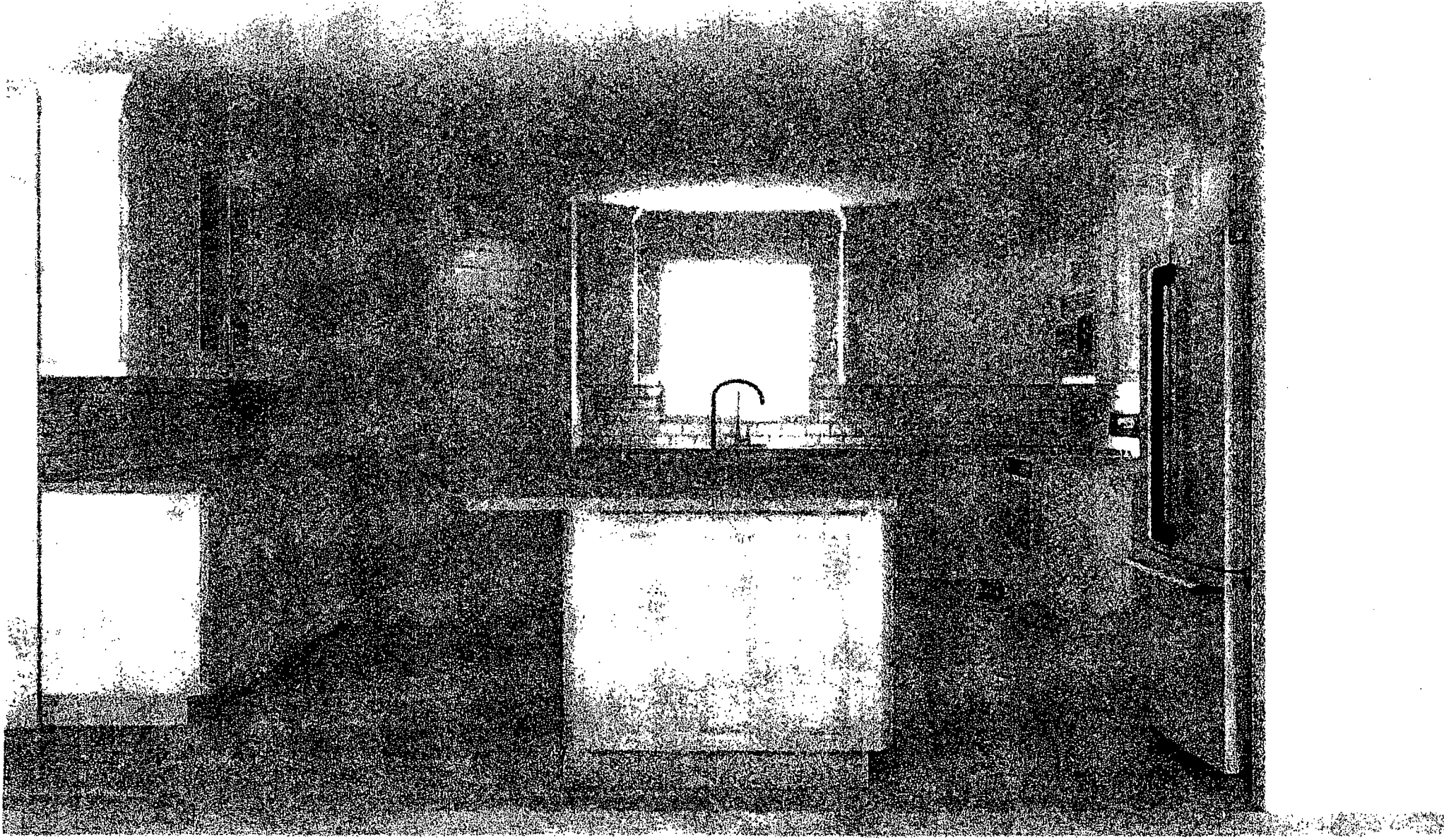

ARTISTIC PICTURE
NOT TO SCALE

2a

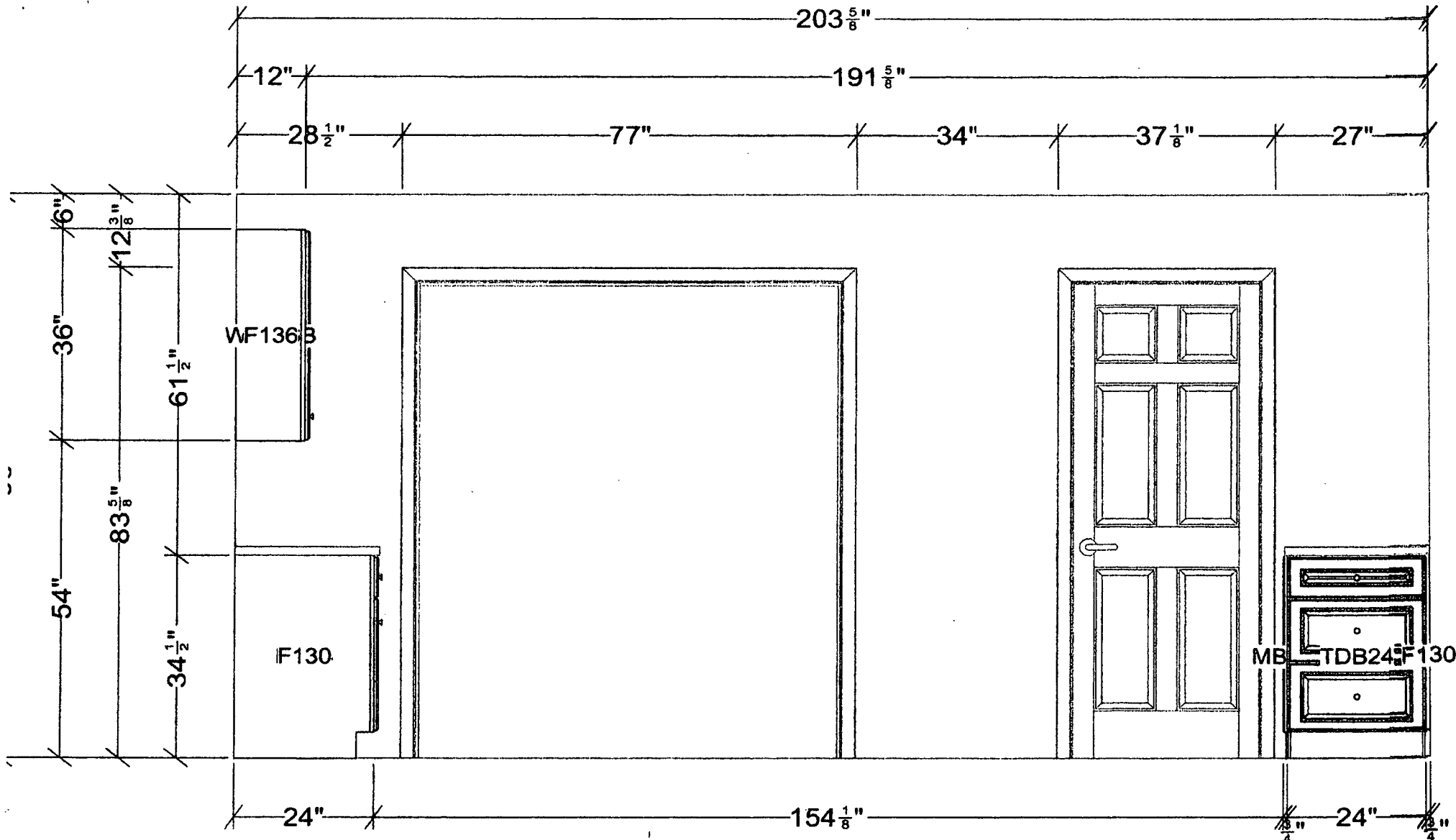

All dimensions and size designations given are subject to verification on job site and adjustment to fit job conditions.

2020

This is an original design and must not be released or copied unless applicable fee has been paid or job order placed.

Designed: 9/11/2019
Printed: 9/11/2019

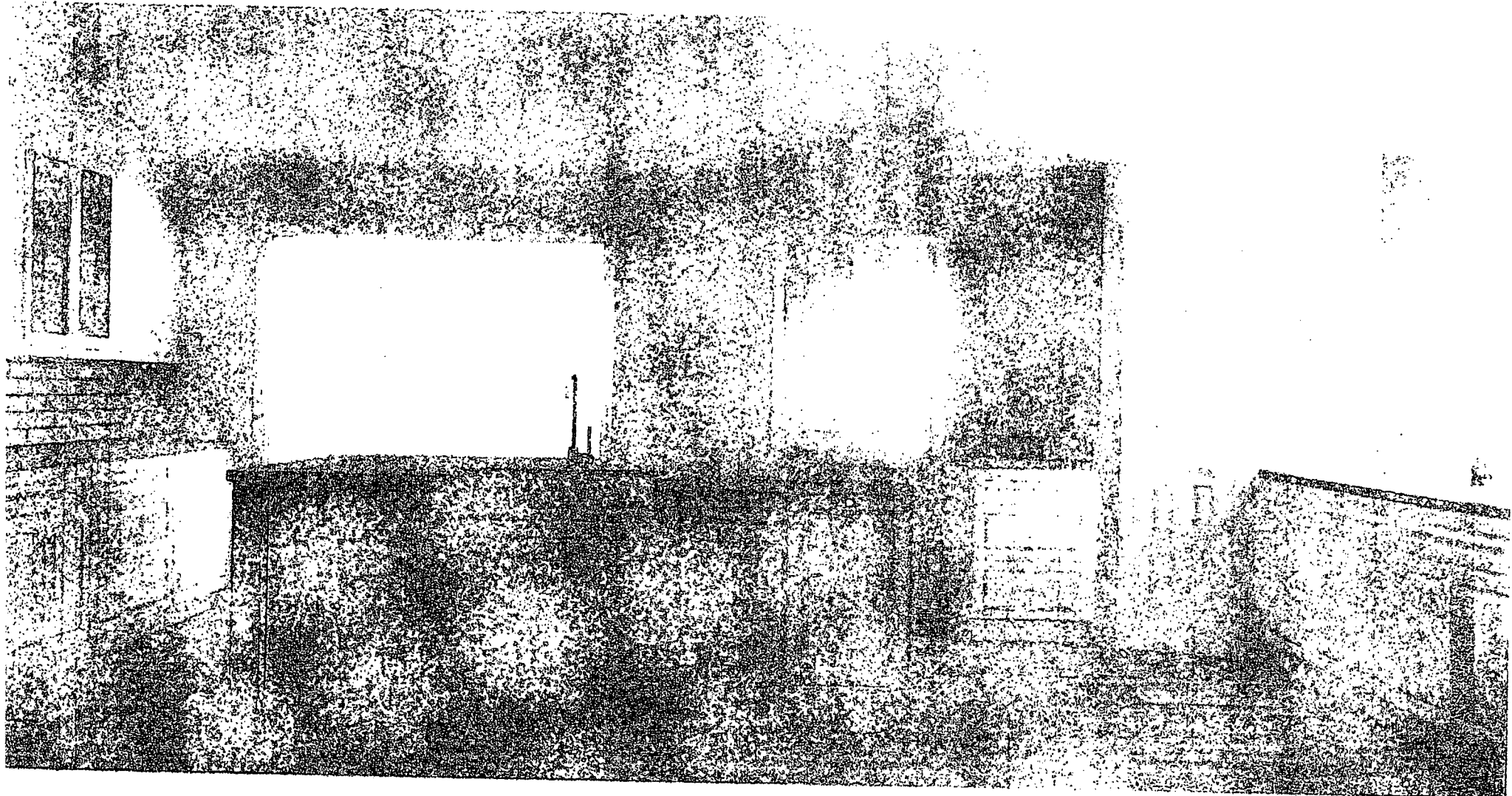

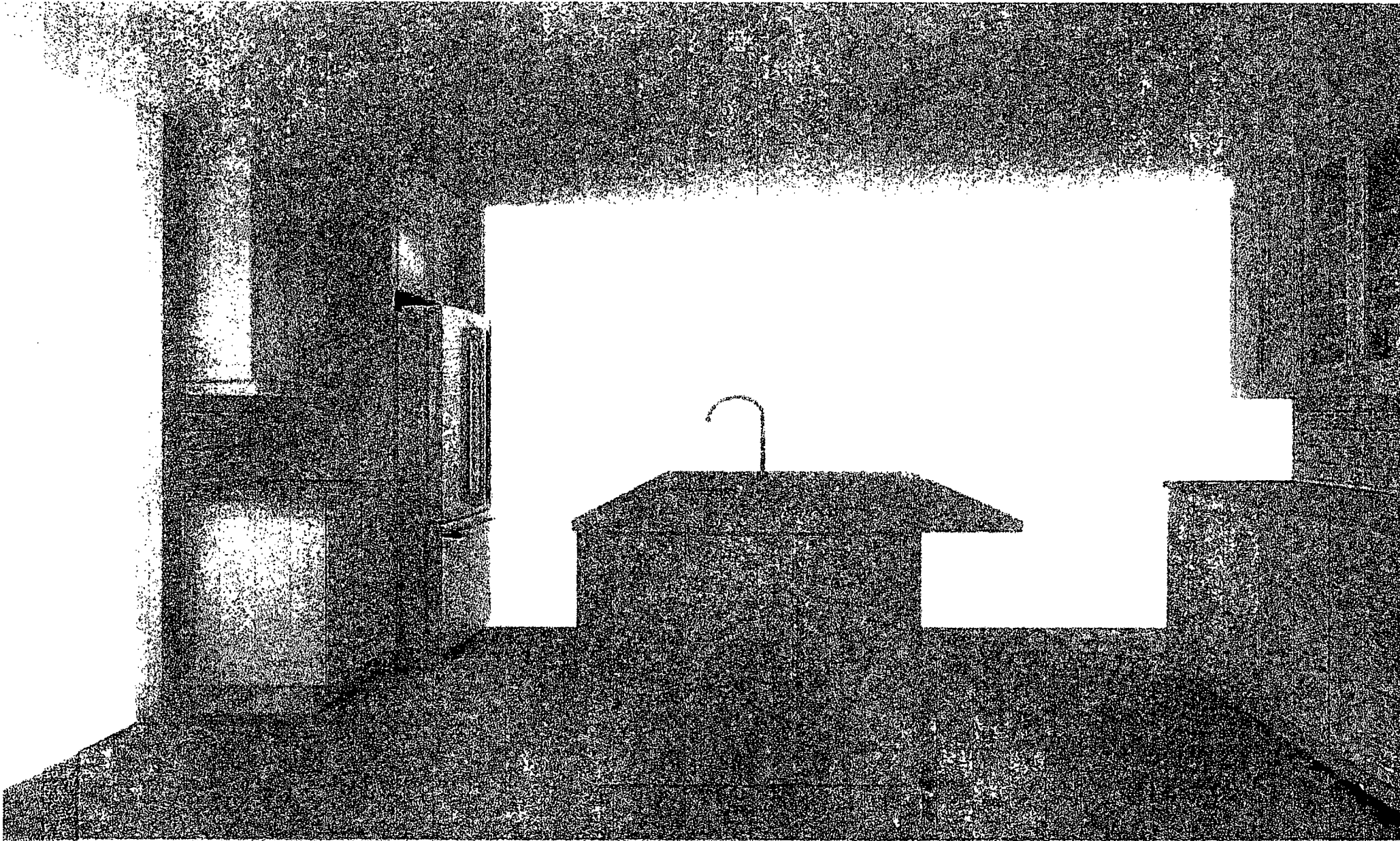

ARTISTIC ~~DRAWING~~ PICTURE NOT TO SCALE

L. K.

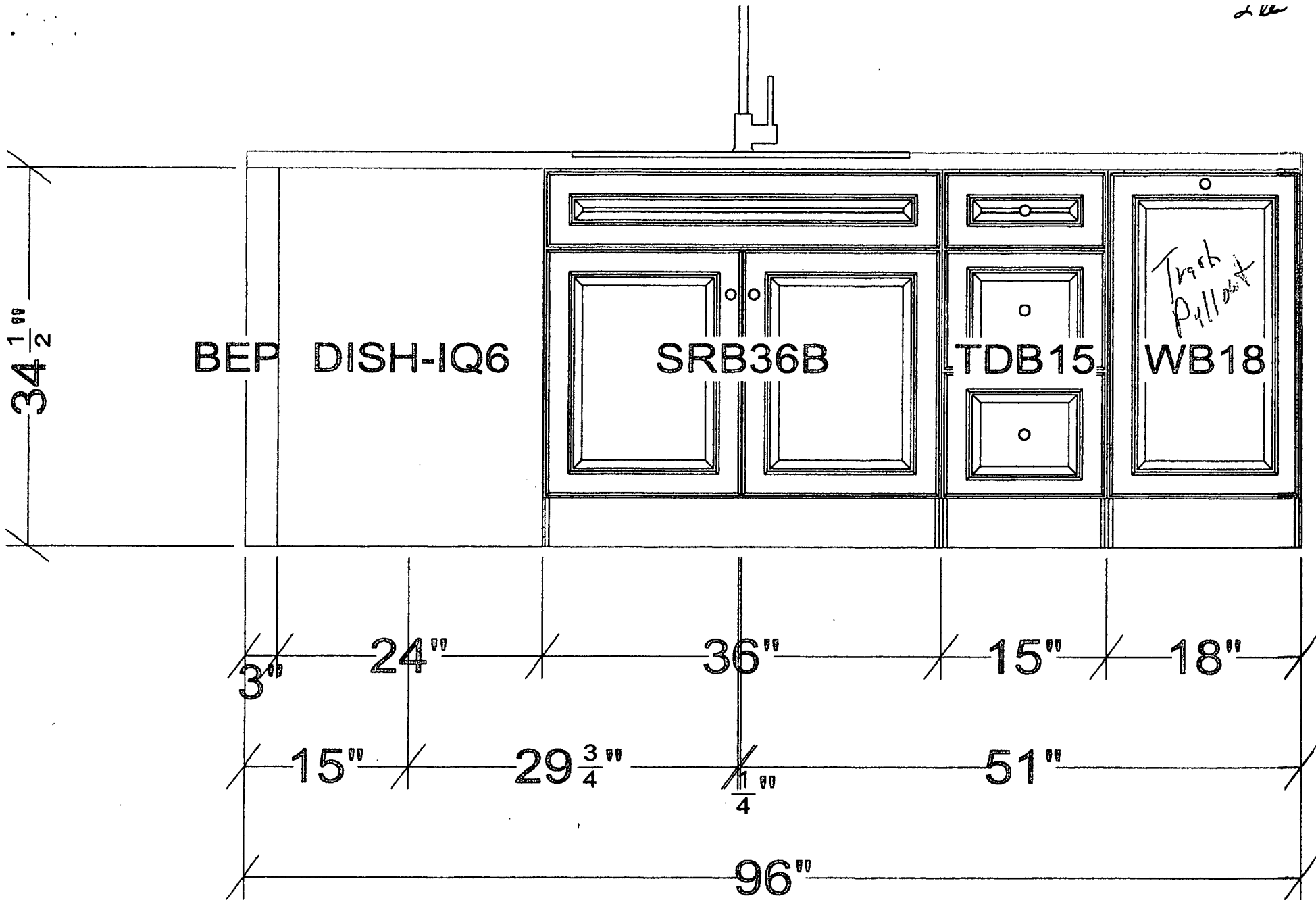

All dimensions size designations given are subject to verification on job site and adjustment to fit job conditions.

2020

This is an original design and must not be released or copied unless applicable fee has been paid or job order placed.

Designed: 9/11/2019
Printed: 9/11/2019

Original

3

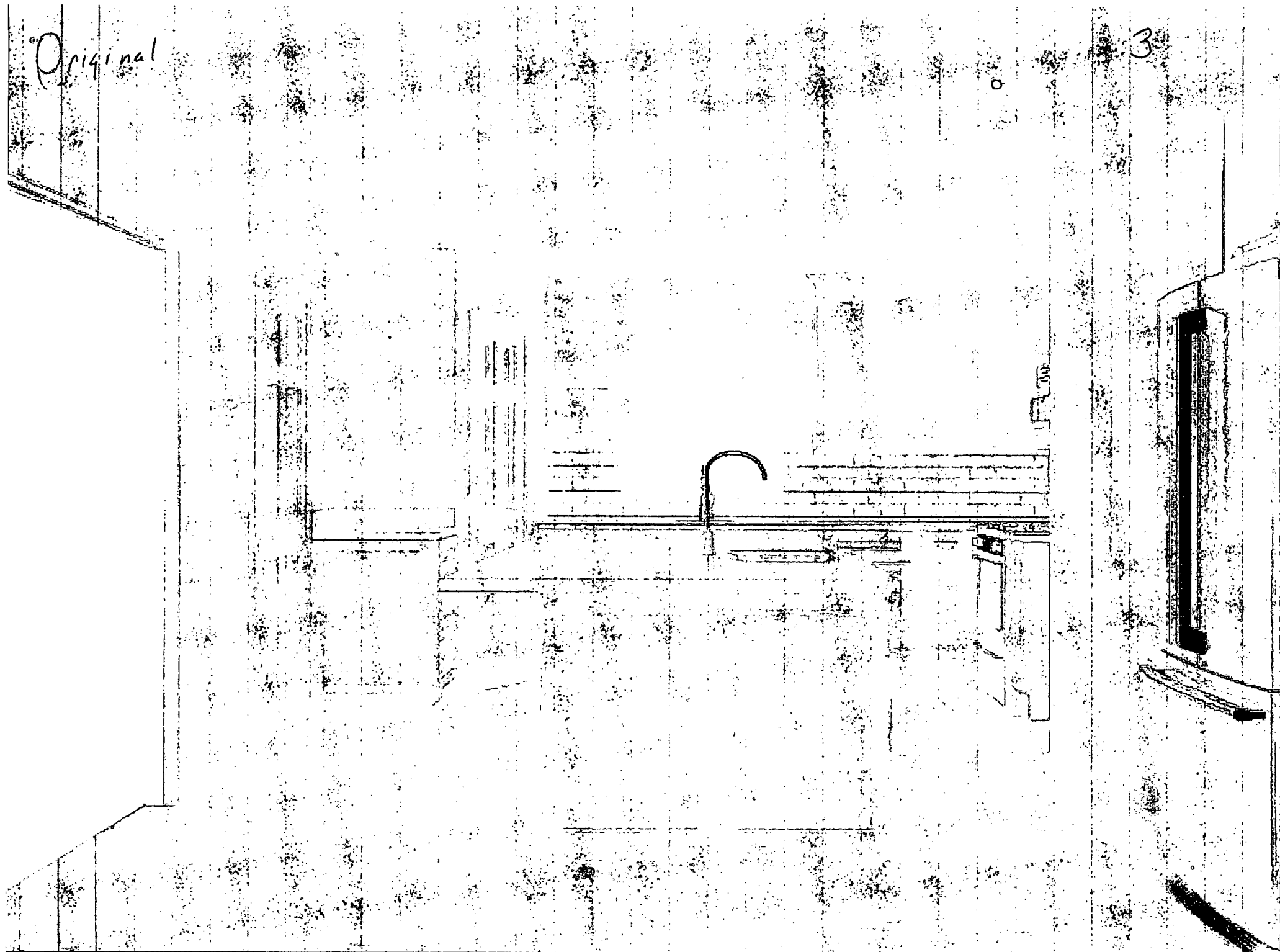

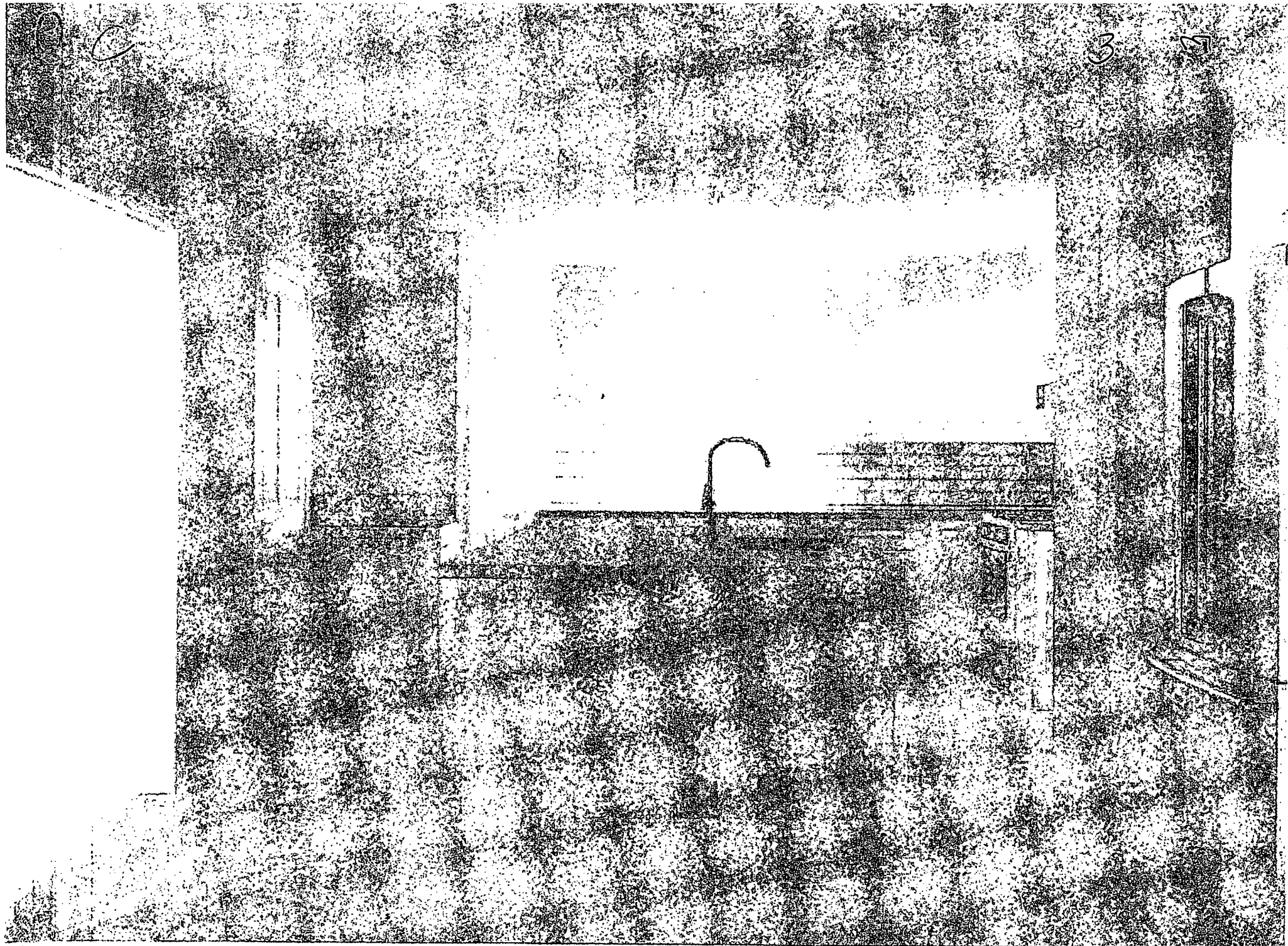

JCL

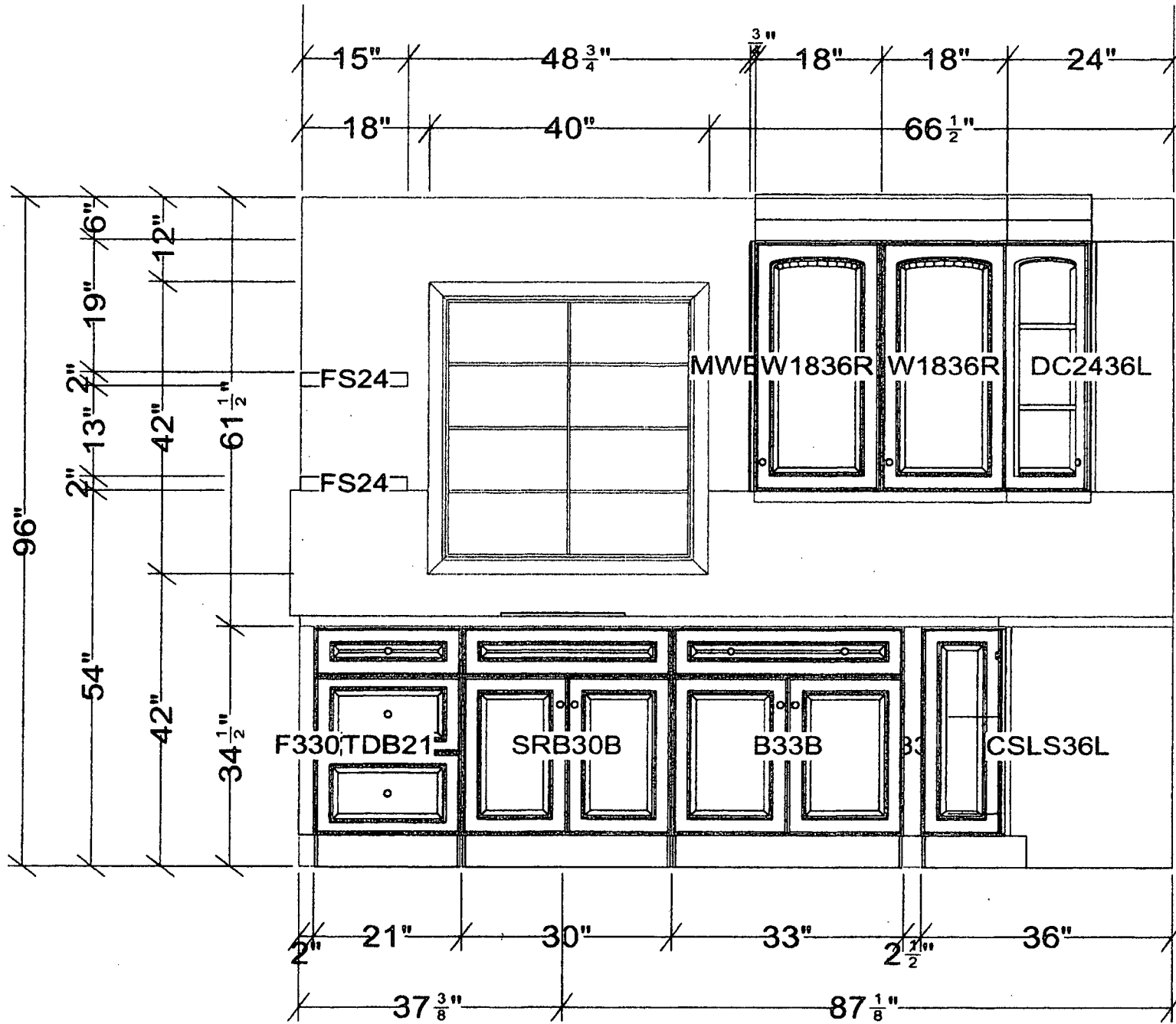

All dimensions and size designations given are subject to verification on job site and adjustment to fit job conditions.

2020

This is an original design and must not be released or copied unless applicable fee has been paid or job order placed.

Designed: 9/11/2019
Printed: 9/11/2019

C

4 H

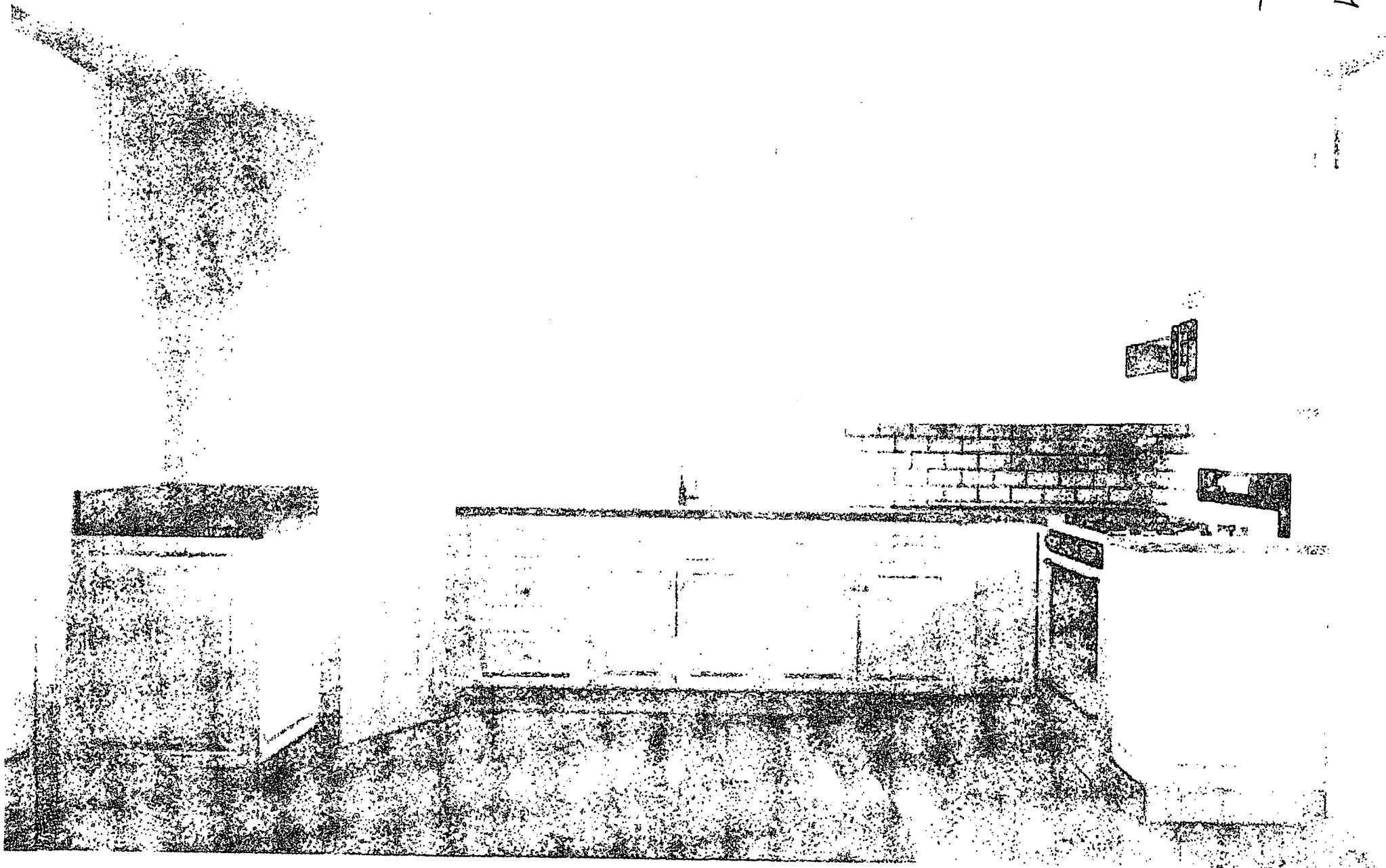

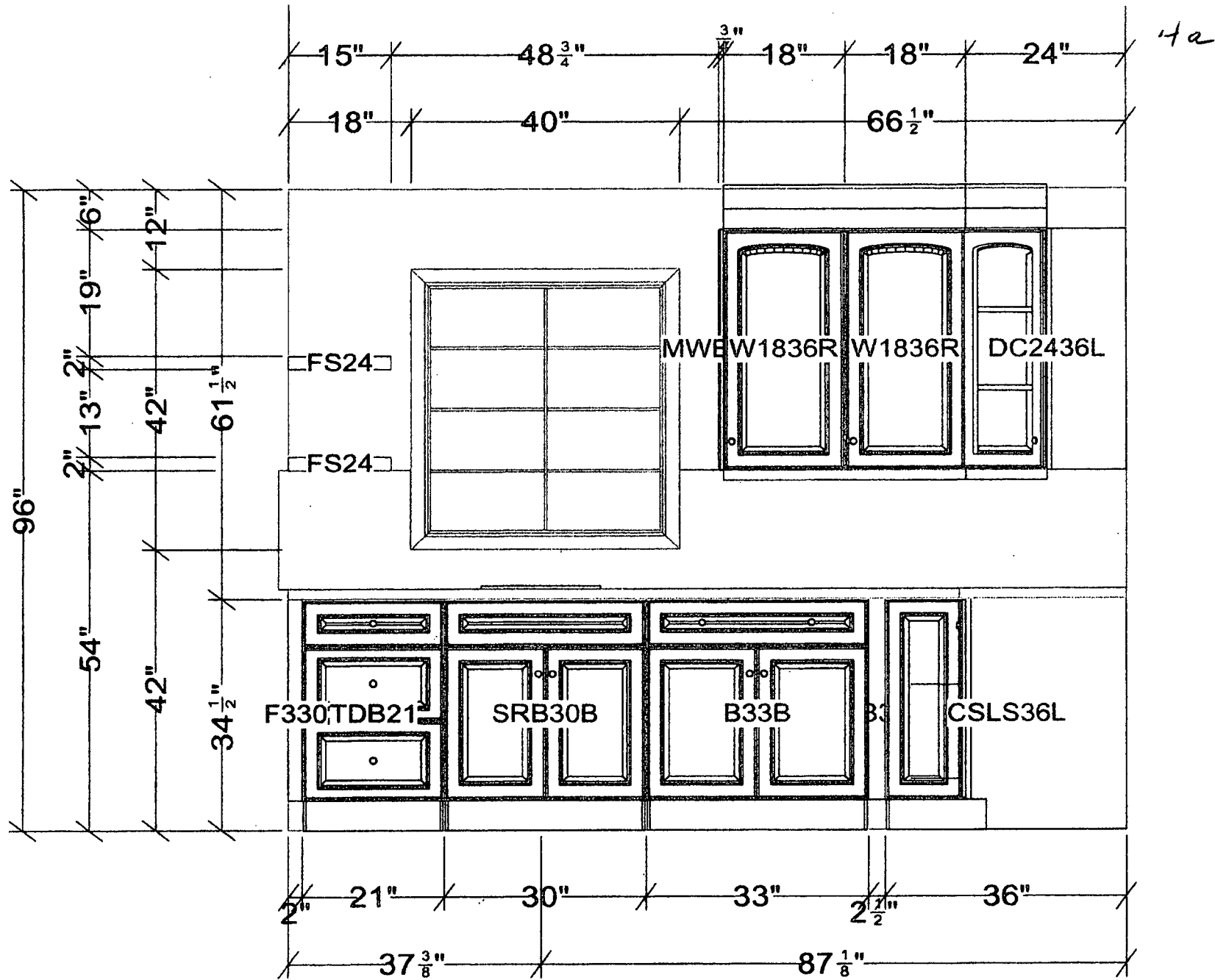

All dimensions & size designations given are subject to verification on job site and adjustment to fit job conditions.

2020

This is an original design and must not be released or copied unless applicable fee has been paid or job order placed.

Designed: 9/11/2019
Printed: 9/11/2019

46

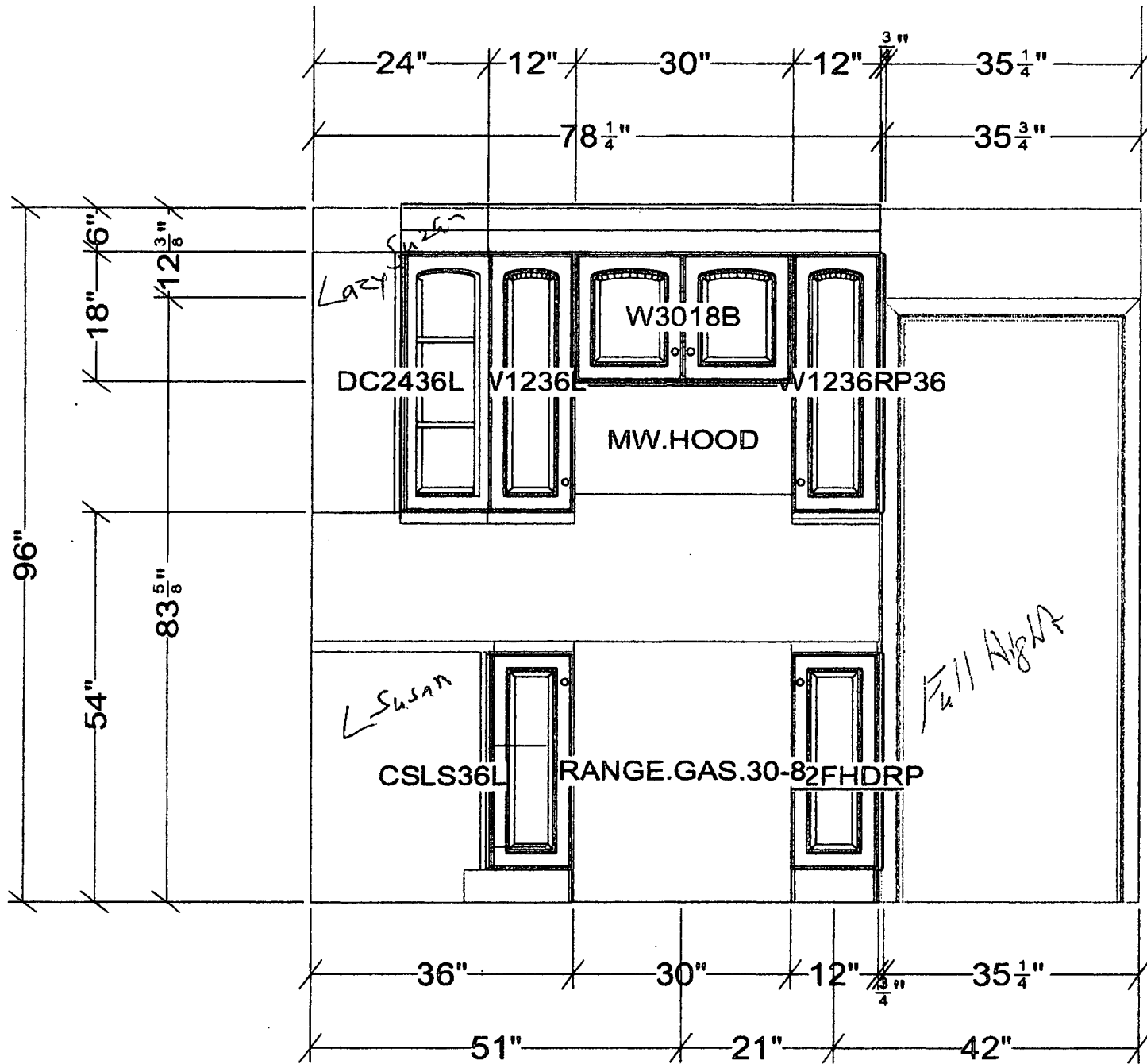

All dimensions size designations given are subject to verification on job site and adjustment to fit job conditions.

2020

This is an original design and must not be released or copied unless applicable fee has been paid or job order placed.

Designed: 9/11/2019
Printed: 9/11/2019

7

515

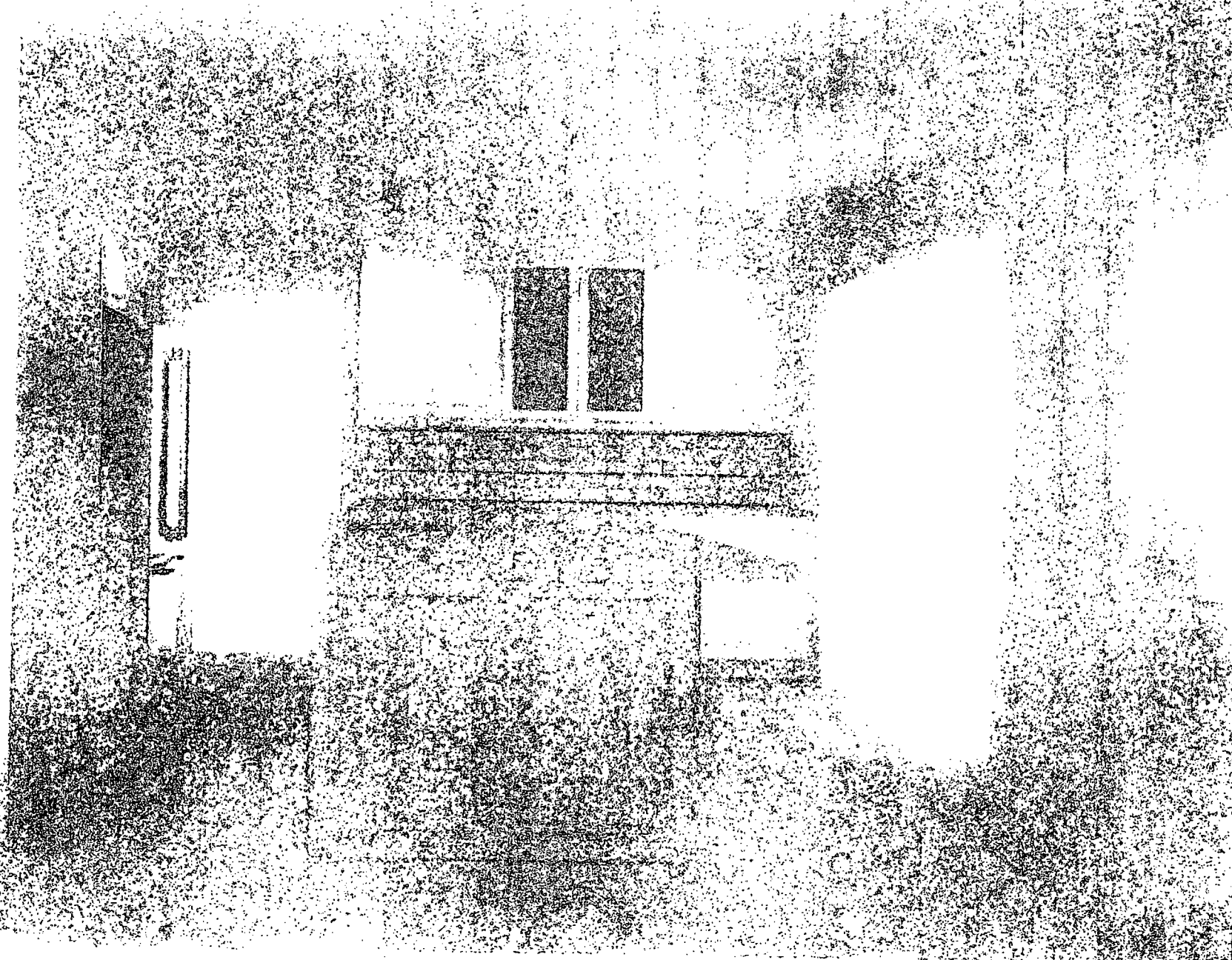

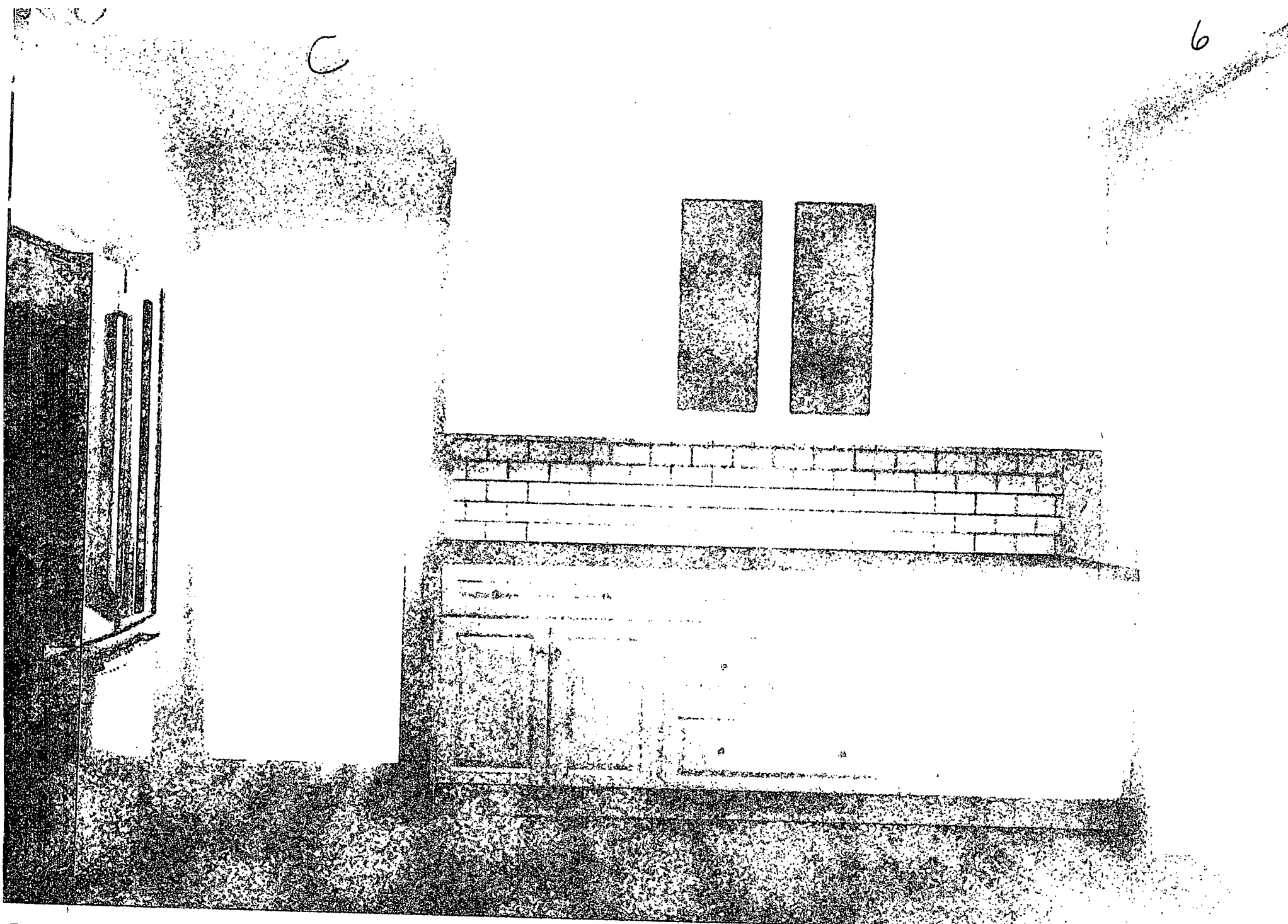

C

6

6

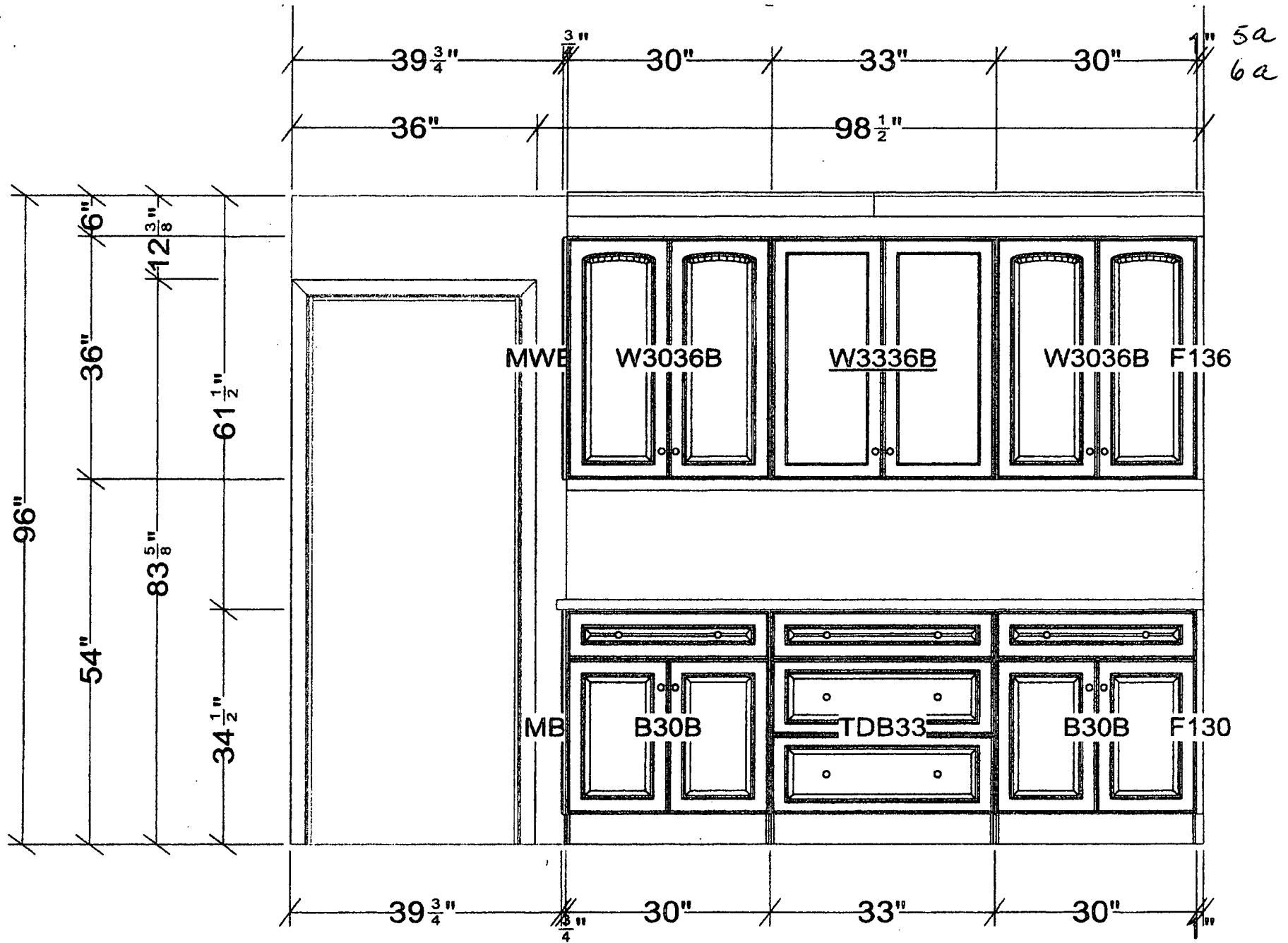

5a
6a

<p>All dimensions and size designations given are subject to verification on job site and adjustment to fit job conditions.</p>	<p>2020</p>	<p>This is an original design and must not be released or copied unless applicable fee has been paid or job order placed.</p>	<p>Designed: 9/11/2019 Printed: 9/11/2019</p>
---	-------------	---	---

20

Copy

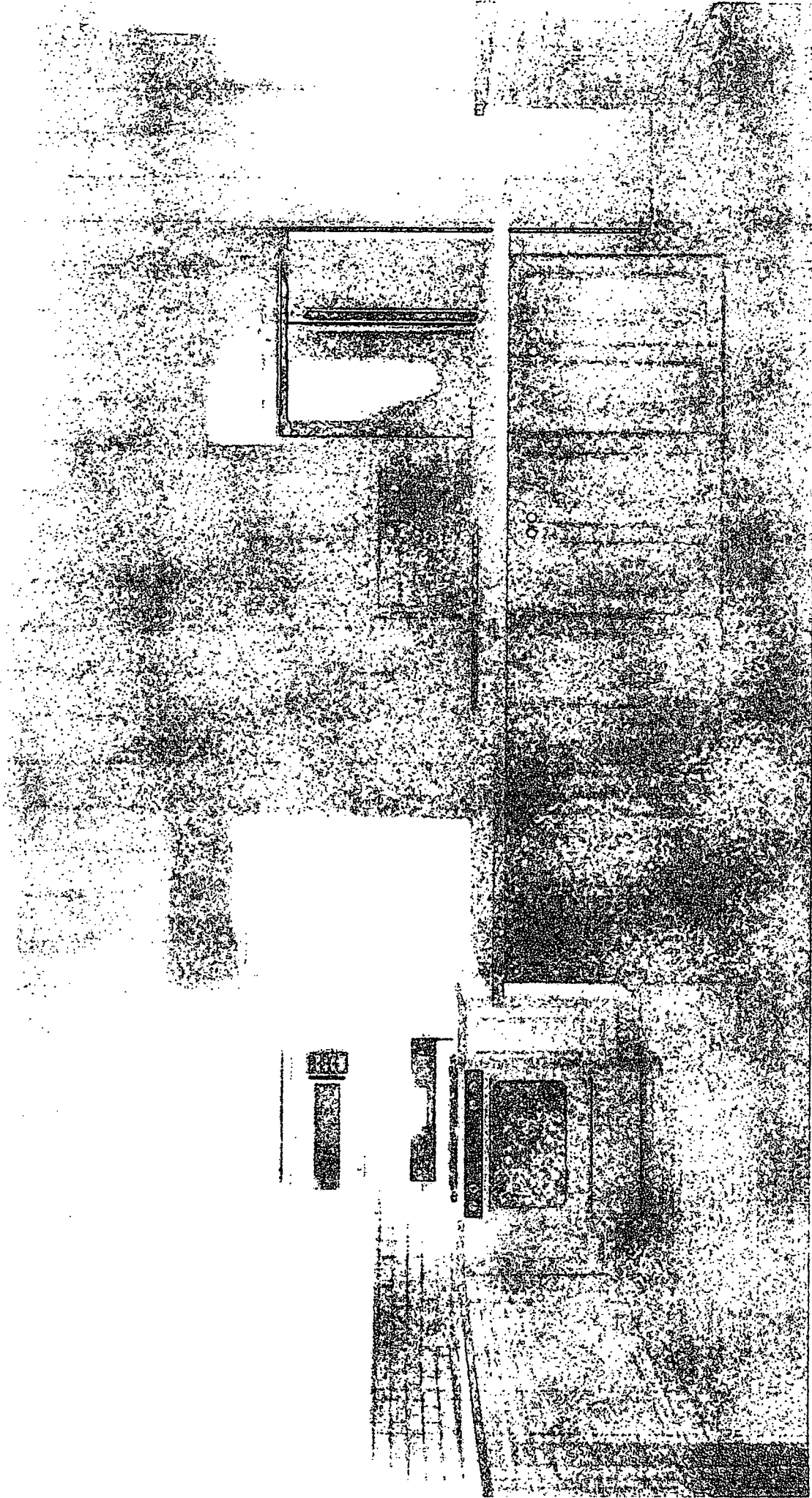

7a

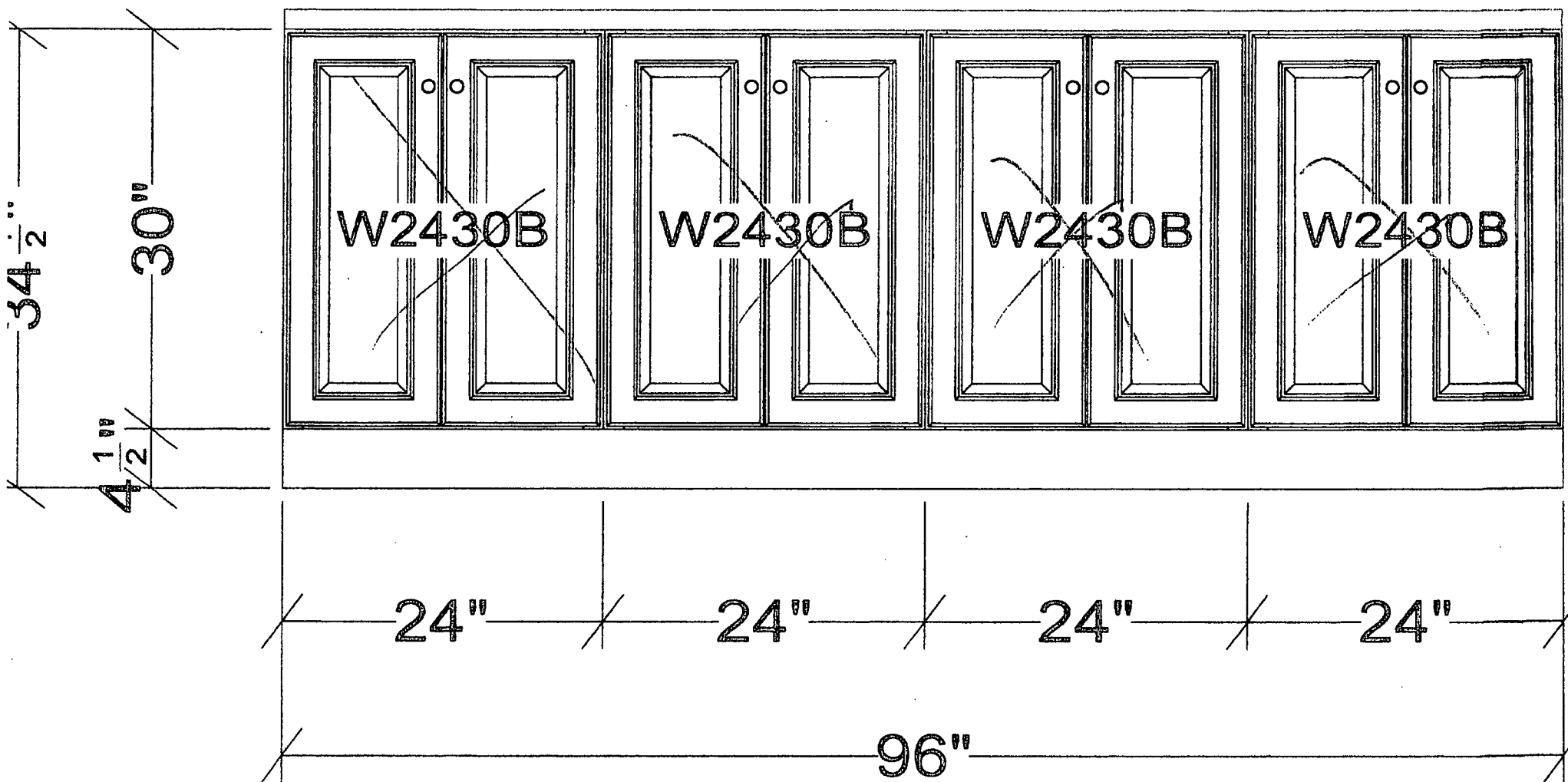

All dimensions and size designations given are subject to verification on job site and adjustment to fit job conditions.

2020

This is an original design and must not be released or copied unless applicable fee has been paid or job order placed.

Designed: 9/11/2019
Printed: 9/11/2019

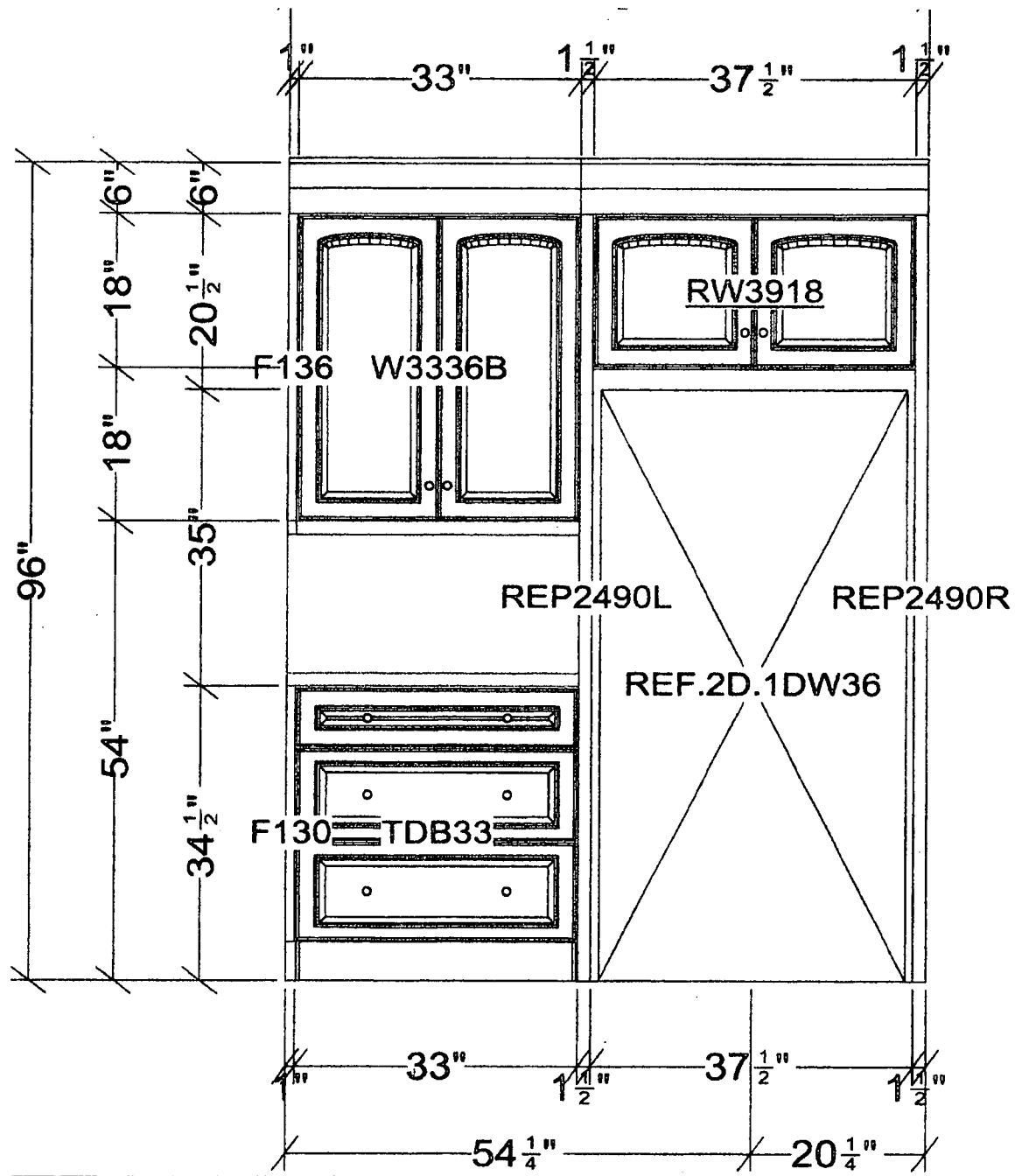

All dimensions and size designations given are subject to verification on job site and adjustment to fit job conditions.

2020

This is an original design and must not be released or copied unless applicable fee has been paid or job order placed.

Designed: 9/11/2019
Printed: 9/11/2019

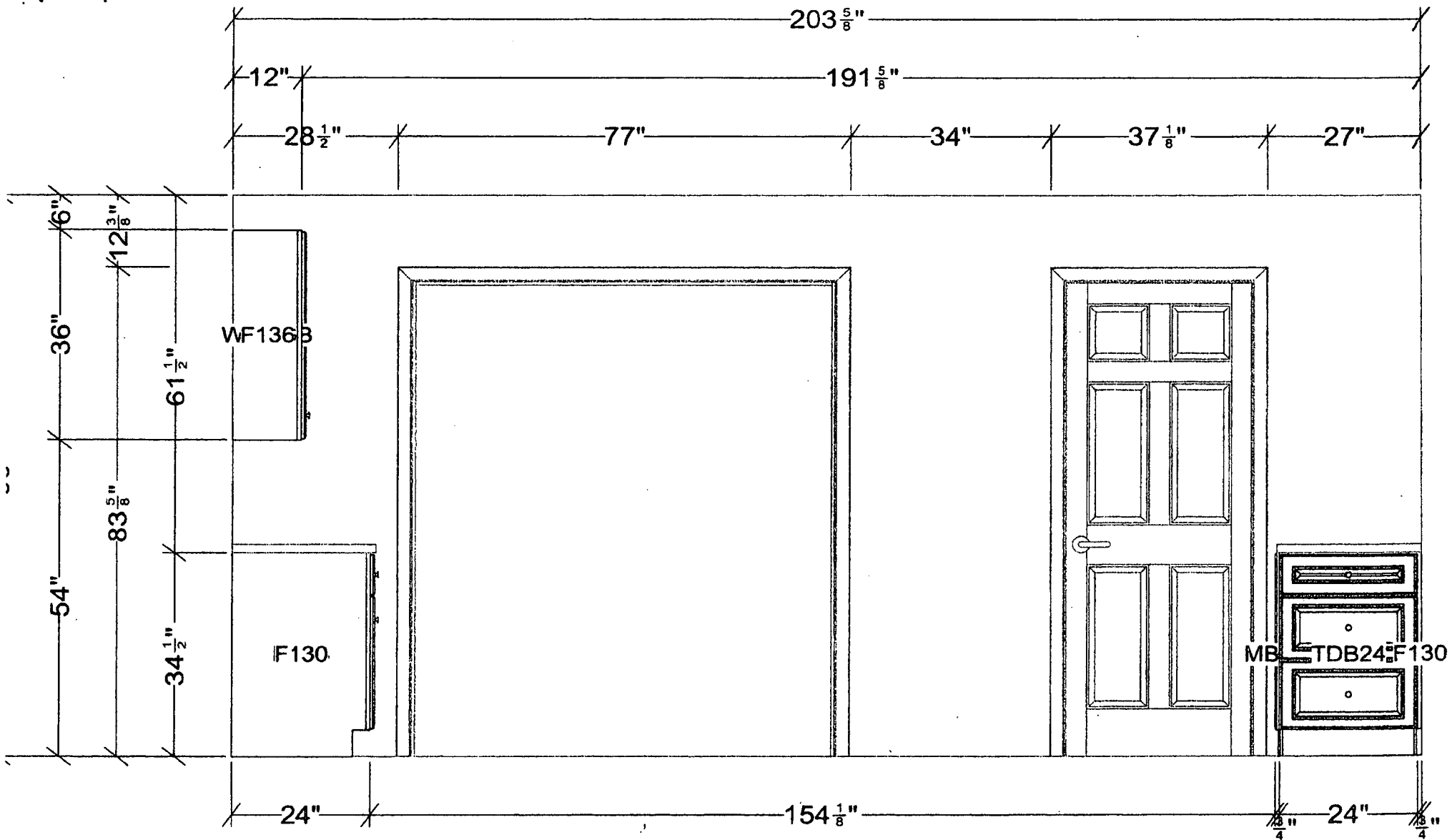

All dimensions and size designations given are subject to verification on job site and adjustment to fit job conditions.

2020

This is an original design and must not be released or copied unless applicable fee has been paid or job order placed.

Designed: 9/11/2019
Printed: 9/11/2019

7C

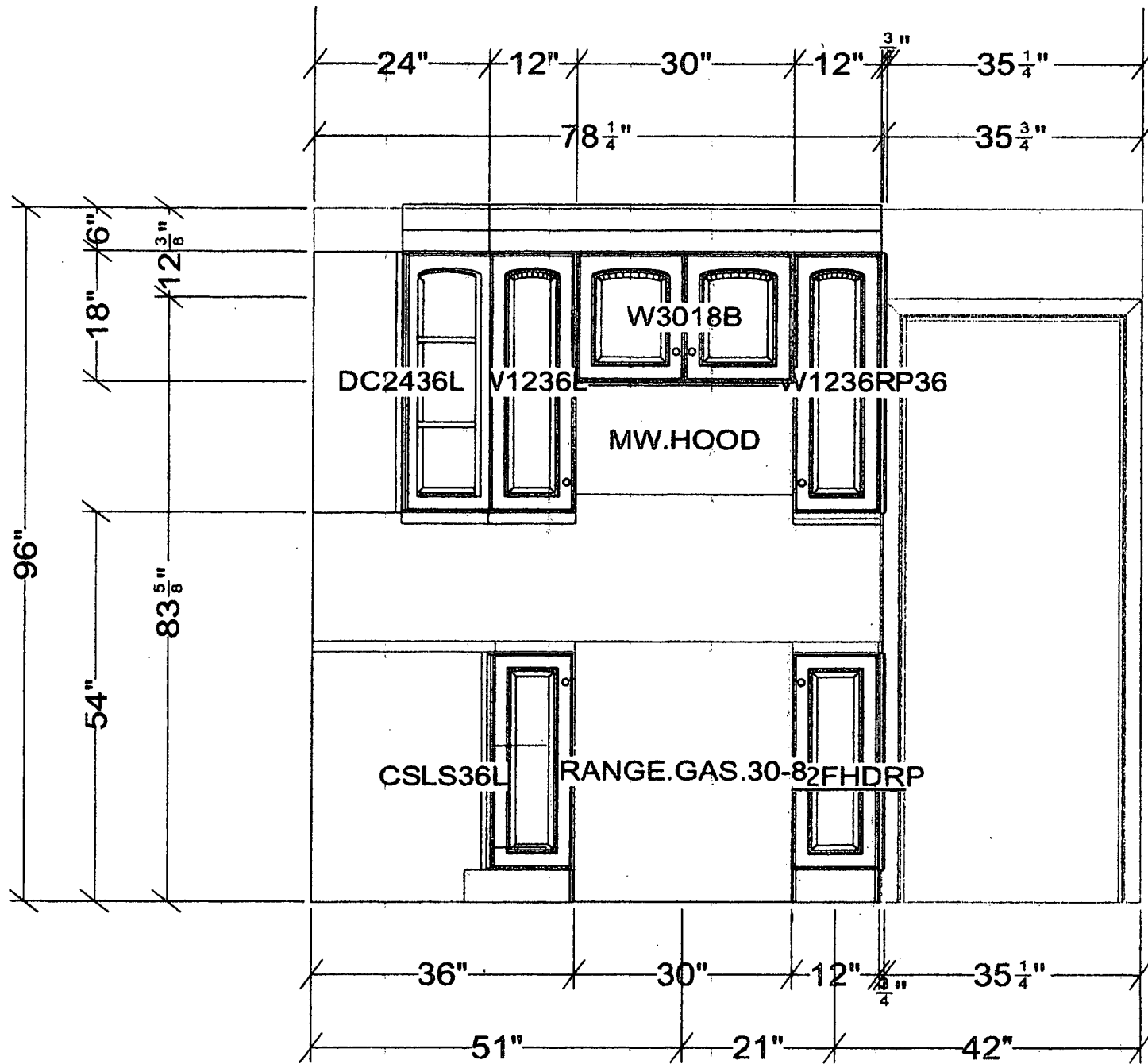

All dimensions size designations given are subject to verification on job site and adjustment to fit job conditions.

2020

This is an original design and must not be released or copied unless applicable fee has been paid or job order placed.

Designed: 9/11/2019
Printed: 9/11/2019

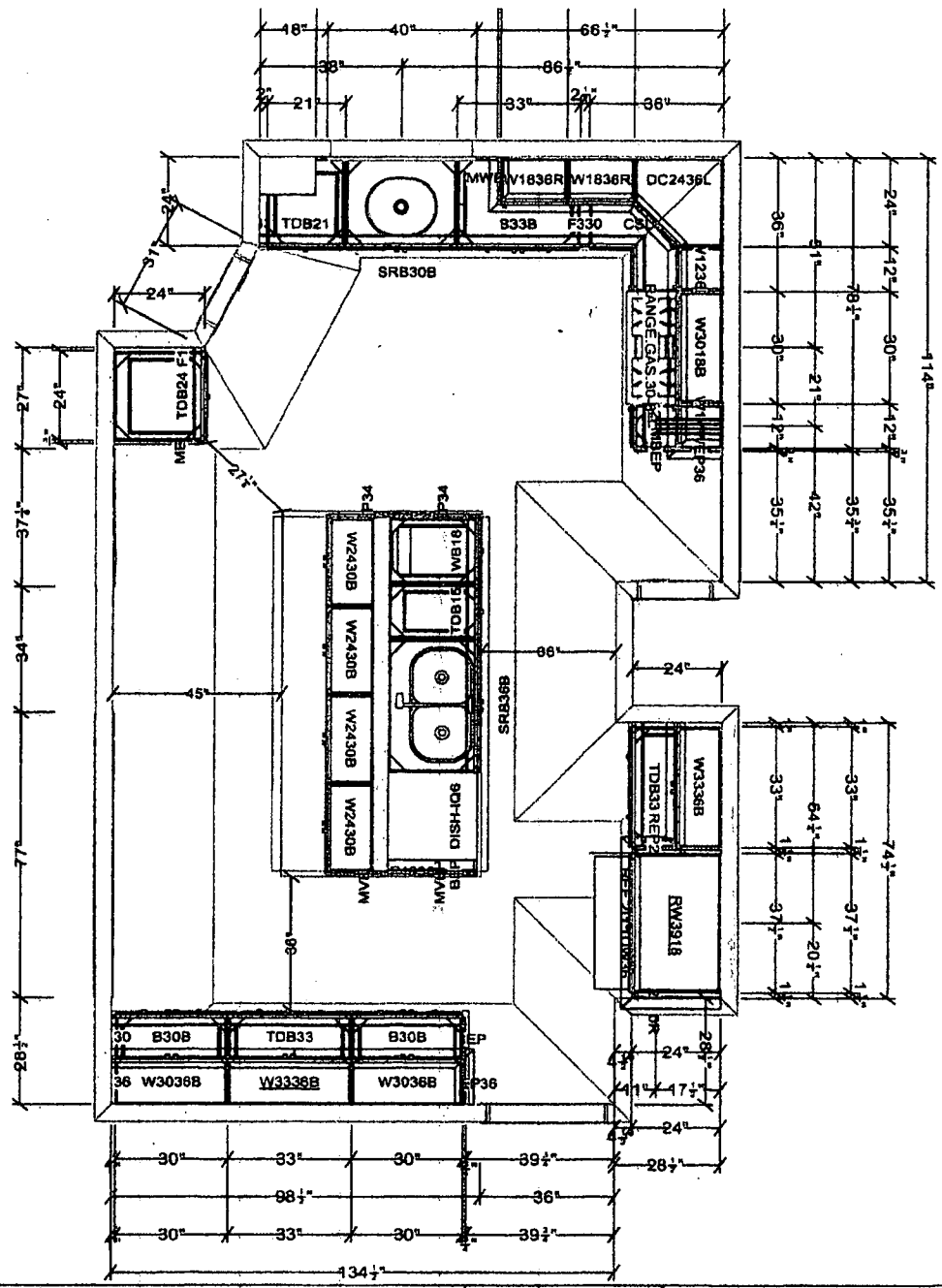

All dimensions size designations given are subject to verification on job site and adjustment to fit job conditions.

2020

This is an original design and must not be released or copied unless applicable fee has been paid or job order placed.

Designed: 9/11/2019
Printed: 9/11/2019

Paid

300.00 Cash

For Cab Drawings &

Consultation

8/20/2019

~~Handwritten signature~~

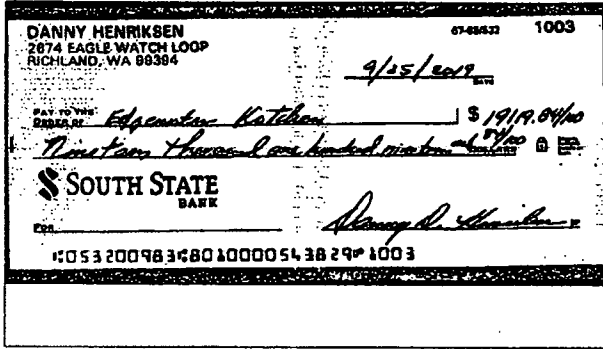

9/26/2019 - 1003 - \$19,119.84

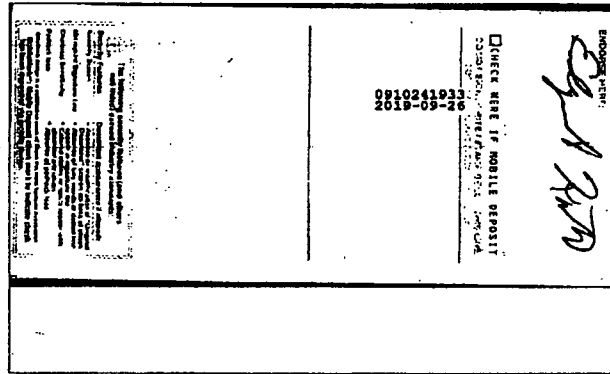

9/26/2019 - 1003 - \$19,119.84

FEB 10 2020 Check #1001

- \$1,000.00

Details

Description:
Check #1001
Date:
2/10/2020
Type:
Debit - Check 1001

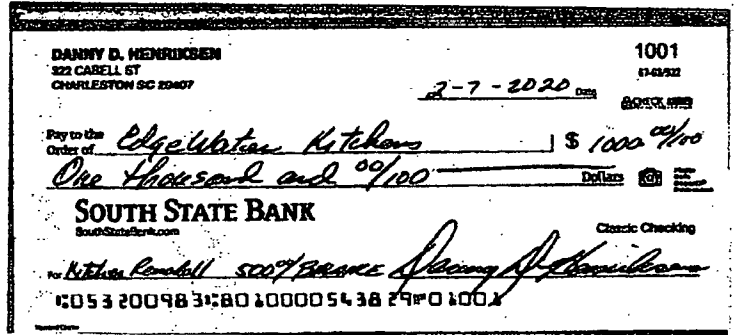

OFFICIAL CHECK



CUSTOMER COPY

67-98/532

11246903

PAY TO THE ORDER OF EDgewater KITCHENS

DATE 12/27/2019

\$6,657.00

\$ 6,657.00 DOLLARS

NOTICE TO THE CUSTOMER: AS A CONDITION TO THIS INSTITUTION'S ISSUANCE OF THIS CHECK, PURCHASER AGREES TO PROVIDE DECLARATION OF LOSS PRIOR TO THE REFUND OR REPLACEMENT OF THIS CHECK IN THE EVENT IT IS LOST, MISPLACED, OR STOLEN. REFUNDS AND REPLACEMENTS CANNOT BE MADE FOR 90 DAYS AFTER ISSUANCE OF ORIGINAL CHECK.

REMITTER DANNY D HENRIKSON

NON-NEGOTIABLE

AUTHORIZED SIGNATURE

COPY

COPY

OFFICIAL CHECK



CUSTOMER COPY

67-98/532

11255308

PAY TO THE ORDER OF EDGE WATER KITCHENS

DATE 01/30/2020

\$2,850.00

\$ 2,850.00 DOLLARS

NOTICE TO THE CUSTOMER: AS A CONDITION TO THIS INSTITUTION'S ISSUANCE OF THIS CHECK, PURCHASER AGREES TO PROVIDE DECLARATION OF LOSS PRIOR TO THE REFUND OR REPLACEMENT OF THIS CHECK IN THE EVENT IT IS LOST, MISPLACED, OR STOLEN. REFUNDS AND REPLACEMENTS CANNOT BE MADE FOR 90 DAYS AFTER ISSUANCE OF ORIGINAL CHECK.

REMITTER DANNY D HENRIKSEN-BALANCE

NON-NEGOTIABLE

AUTHORIZED SIGNATURE

COPY

COPY

OFFICIAL CHECK



CUSTOMER COPY

67-98/532

11254045

PAY TO THE ORDER OF EDGEWATER KITCHEN

DATE 01/24/2020

\$1,733.00

\$ 1,733.00 DOLLARS

NOTICE TO THE CUSTOMER: AS A CONDITION TO THIS INSTITUTION'S ISSUANCE OF THIS CHECK, PURCHASER AGREES TO PROVIDE DECLARATION OF LOSS PRIOR TO THE REFUND OR REPLACEMENT OF THIS CHECK IN THE EVENT IT IS LOST, MISPLACED, OR STOLEN. REFUNDS AND REPLACEMENTS CANNOT BE MADE FOR 90 DAYS AFTER ISSUANCE OF ORIGINAL CHECK.

REMITTER DANNY D HENRIKSEN

BALANCE DUE 4,000

NON-NEGOTIABLE

AUTHORIZED SIGNATURE

COPY

COPY

From: Edgewater Kitchens
Sent: Tuesday, September 10, 2019 8:04 AM
To: ddhenri70@hotmail.com; edgewk@gmail.com
Subject: Invoice 1007 from Edgewater Kitchens

Edgewater Kitchens

Dear Dan Hendrickson,

Here's your invoice! We appreciate your prompt payment.

Thanks for your business!
Edgewater Kitchens

INVOICE 1007 DETAILS

DUE 09/10/2019

\$29,119.84

10

Print or save

Powered by QuickBooks

Bill to

Dan Hendrickson

From: Magnus Shier
Sent: Wednesday, September 11, 2019 1:20 PM
To: Danny Henriksen
Subject: Re: Question about invoice 1007

Yes, that is correct. The due now amount is in the memo.

Magnus Shier

On Wed, Sep 11, 2019 at 1:15 PM Danny Henriksen <ddhenri70@hotmail.com> wrote:

Magnus,

The invoice does not reflect the payment schedule we discussed in our last meeting, I thought we discussed paying the 19,119.84 initially and for payments of 2500 for week 1, 2500 for week 2 and 5000.00 at the completion of the job.

Thank you,

Dan Henriksen

Sent from Mail for Windows 10

Edgewater Kitchens

2487 Ashley River RD.
Charleston, SC 29414 US
edgewk@gmail.com
edgewaterkitchens.com

INVOICE

BILL TO

Dan Hendrickson

INVOICE # 1007

DATE 09/10/2019

DUE DATE 09/10/2019

TERMS Due on receipt

ACTIVITY	DESCRIPTION	QTY	RATE	AMOUNT
Quartz Countertops	Cost plus 15%	54	95.00	5,130.00
Cabinetry Cab Craft	See Design Layout	1	19,119.84	19,119.84
Walled Pantry	Walled Pantry	1	2,500.00	2,500.00
Cabinetry Installation	Cabinetry installation	1	2,370.00	2,370.00

Total job due upon receipt 19119.84

BALANCE DUE

\$29,119.84

Edgewater Kitchens
 2487 Ashley River RD.
 Charleston, SC 29414 US
 edgewk@gmail.com
 edgewaterkitchens.com

INVOICE

BILL TO
 Dan Hendrickson

INVOICE # 1007
DATE 09/10/2019
DUE DATE 10/10/2019
TERMS Net 30 (5)

ACTIVITY	DESCRIPTION	QTY	RATE	AMOUNT
Quartz Countertops	At Cost	94	80.00	7,520.00
Cabinetry Cab Craft	See Design Layout	1	19,119.84	19,119.84
Walled Pantry	Walled Pantry	1	2,500.00	2,500.00
Cabinetry Installation	Cabinetry installation	1	2,370.00	2,370.00

Total job due upon receipt 19119.84

BALANCE DUE

\$31,509.84

Countertop Deposit 3814.00
 Cabinet Removal Deposit 350.00
 1/2 Paint + Cab Install 2500.00
 6657.00

19119.84
 6657.00

 25776.84

31509.84
 25776.84

 5733.00

65 sq ft.
 Counter TOP
 Installed.

Edgewater Kitchens
2487 Ashley River RD.
Charleston, SC 29414 US
edgewk@gmail.com
edgewaterkitchens.com

INVOICE

BILL TO
Dan Hendrickson

INVOICE # 1007
DATE 09/10/2019
DUE DATE 09/10/2019
TERMS Due on receipt

ACTIVITY	DESCRIPTION	QTY	RATE	AMOUNT
Quartz Countertops	At Cost Counters	62	80.00	4,960.00
Cabinetry Cab Craft	See Design Layout	1	19,119.84	19,119.84
Walled Pantry	Walled Pantry	1	2,500.00	2,500.00
Cabinetry Installation	Cabinetry installation	1	2,370.00	2,370.00
Payment Agreement	Deposit 19,000.00 To Start, Week 1 Draw 2500.00, Week 2 Draw 2489.84	1	0.00	0.00
Quartz Countertops	At Cost Island	32	80.00	2,560.00

Deposit due upon receipt 19,000.00

BALANCE DUE

\$31,509.84

Counter Suit

March 2, 2021

To: Honorable Judge Jefferson, Deadra L.
Ninth Judicial Court
Charleston, S.C.29401

From: Danny D. Henriksen, Defendant
322 Cabell St.
Charleston, S.C. 29407

FILED
2021 MAR -2 PM 2:06
JULIEN SHERIFF
CLERK OF COURT
BY

Dear Judge Jefferson

Please find the enclosed figures for a counter suit for civil action 2020-CP-10-5405, Magnus Shier, plaintiff, Vs Danny D. Henriksen, defendant. I understand these figures are conditional only if I should prevail and awarded by the court.

- 1. Interest on decision 6958 X 0.24 = \$1670.00
Beginning February 2020 ending February 2021
- 2. Sheriff's fees to enforce sale \$ 800.00
- 3. Filing fee Clerk of Court \$ 35.00
- 4. Sherriff's office execution of property order.
\$ 25.00
- Total \$2530.00

Thank you,

Sincerely,



Danny D. Henriksen
Defendent

believes the court has misunderstood, failed to fully consider, or perhaps failed to rule on an argument or issue, and the party wishes for the court to reconsider or rule on it. A party *must* file such a motion when an issue or argument has been raised, but not ruled on, in order to preserve it for appellate review.” Elam v. South Carolina Dept. of Transp., 361 S.C. 9, 24, 602 S.E.2d 772, 780 (2004) (emphasis in original). “A party cannot use a motion to reconsider to present an issue he could have raised prior to judgment but did not.” Anderson Memorial Hosp., Inc. v. Hagen, 313 S.C. 497, 498, 443 S.E. 2d 399, 400 (Ct. App. 1994) (citing C.A.H. v. L.H., 315 S.C. 389, 434 S.E. 2d 268 (1993)); See also Arnold v. State, 309 S.C. 157, 172–73, 420 S.E.2d 834, 842 (1992).

“A motion to alter or amend the judgment shall be served not later than 10 days after receipt of written notice of the entry of the order.” Rule 59(e), SCRCF. “[T]he ten-day deadline in Rule 59(e) is an absolute deadline. A trial court does not have the power to alter or amend a final order if more than ten days passes and no Rule 59(e) motion has been served, nor does a trial court have any power to grant the moving party an extension of time in which to file a Rule 59(e) motion.” Overland, Inc. v. Nance, 423 S.C. 253, 256-57, 815 S.E.2d 431, 433 (2018) (citation omitted) (citing Leviner v. Sonoco Prods. Co., 339 S.C. 492, 530 S.E.2d 127 (2000)).

“A party filing a written motion under this rule shall provide a copy of the motion to the judge within ten (10) days after the filing of the motion.” Rule 59(g), SCRCF; See also Smith v. Fedor, 422 S.C. 118, 126, 809 S.E.2d 612, 161 (Ct. App. 2017) (“Rule 59(g) would lack any purpose if trial courts committed error by denying the motion for failure to comply with the rule. Further, our language in Gallagher v. Evert, 353 S.C. 59, 63-64, 577 S.E.2d 217, 219 (Ct. App. 2002) implies a trial court may deny the motion solely on the basis of the rule.”).

I. The Appellant’s Motion for Reconsideration is Granted.

This matter was originally scheduled to come before the Court on January 25, 2021 on Appellant’s Notice of Civil Appeal, filed December 9, 2020. Pursuant to the Chief Justice’s April

3, 2020 Order, As Amended December 16, 2020, this matter was scheduled to be heard via WebEx on January 27, 2021 to accommodate the pro se Appellant and pro se Respondent.

The Court obtained the Appellant's phone number from the Notice of Appeal on file. Inadvertently, the Court misread the Appellant's phone number and attempted to contact the Appellant via an incorrect phone number multiple times prior to the hearing to give the Appellant the login information for the WebEx hearing. The Court left several messages at the incorrect phone number and was unable to make contact with the Appellant, as the phone number the Court used to contact the Appellant was disconnected and no longer in service.

Accordingly, because the Court was unable to contact the Appellant, and the Appellant failed to appear at the call of the case, the Court was under the impression that the Appellant willfully failed to appear, and the Court issued an Order on January 29, 2021 dismissing the Appellant's appeal for failure to prosecute. The Court's Order gave the Appellant ten (10) days from the receipt of the Order to challenge the relief contained in the Court's Order.

Upon receipt of the Appellant's Motion for Reconsideration, the Court discovered that it misread the phone number provided by the Appellant in his Notice of Appeal, and therefore the Court was dialing the incorrect phone number in its attempts to reach the Appellant prior to the hearing.

Accordingly, good cause having been shown by the Appellant, and pursuant to the terms of the Court's January 29, 2021 Order giving the Appellant ten (10) days from receipt of the Order to challenge the Court's dismissal of the Appellant's appeal, the Appellant's Motion for Reconsideration is Granted, the Court's January 29, 2021 Order is vacated, and the Appellant's appeal is restored to the active docket.

CONCLUSION

Therefore, for the foregoing reasons, and pursuant to Rule 59(e), SCRCP, the Appellant's Motion for Reconsideration is Granted and the Appellant's appeal is restored to the active docket.

AND IT IS SO ORDERED.

Hon. Deadra L. Jefferson
Presiding Judge
Ninth Judicial Circuit

February _____, 2021
Charleston, South Carolina
At Chambers



Charleston Common Pleas

Case Caption: Magnus E Shier III VS Danny D Henrickson , defendant, et al

Case Number: 2020CP1005405

Type: Order/Other

IT IS SO ORDERED.

s/D.L. Jefferson Ninth Judicial Circuit Judge 2128



Edgewater Kitchens
2487 Ashley River Road
Charleston, S.C. 29414

JULIE J. JARVIS, ROR
CLERK OF COURT

2021 FEB -1 PM 2: 10

FILED

Honorable D.L. Jefferson
Ninth Judicial Judge 2128
Charleston, S.C. 29410

Dear Judge Jefferson:

I am appealing to you for an opportunity to reconsider my case number 2020CP1005405. I did not receive the court papers in the mail. My phone # 843-364-3700 has been in service without interruption for over 15 years and no message was left. The phone number 843-300-5725 comes up as a scam likely on my phone or I would have returned the call.

Thank you for your time,

Sincerely,

Magnus Shier
President

Edgewater Kitchens
2487-D Ashley River Road
Charleston, SC 29414
843 225 6263

(1/11/11)
1/11/11 11:11
1/11/11 11:11

Today

11:11 AM Incoming Call
4 minutes

Share Contact

Create New Contact

Add to Existing Contact

Add to Favorites / Contacts

Share My Location

Block this Caller



Favorite



Call



Contact



Call

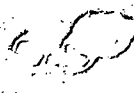

Share My Location

Magnus E Shier, III
PLAINTIFF(S)

Danny D Henrickson et al
DEFENDANT(S)

DISPOSITION TYPE (CHECK ONE)

- JURY VERDICT.** This action came before the court for a trial by jury. The issues have been tried and a verdict rendered.
- DECISION BY THE COURT.** This action came to trial or hearing before the court. The issues have been tried or heard and a decision rendered.
- ACTION DISMISSED (CHECK REASON):** Rule 12(b), SCRPC; Rule 41(a), SCRPC (Vol. Nonsuit); Rule 43(k), SCRPC (Settled);
 Other
- ACTION STRICKEN (CHECK REASON):** Rule 40(j), SCRPC; Bankruptcy;
 Binding arbitration, subject to right to restore to confirm, vacate or modify arbitration award;
 Other
- STAYED DUE TO BANKRUPTCY**
- DISPOSITION OF APPEAL TO THE CIRCUIT COURT (CHECK APPLICABLE BOX):**
 Affirmed; Reversed; Remanded;
 Other Dismissed for Failure to Prosecute

NOTE: ATTORNEYS ARE RESPONSIBLE FOR NOTIFYING LOWER COURT, TRIBUNAL, OR ADMINISTRATIVE AGENCY OF THE CIRCUIT COURT RULING IN THIS APPEAL.

IT IS ORDERED AND ADJUDGED: See attached order (formal order to follow) Statement of Judgment by the Court:

This matter was scheduled to come before the Court on January 25, 2021 on Appellant Magnus E. Shier III's Notice of Civil Appeal, filed December 9, 2020. Pursuant to Chief Justice Beatty's April 3, 2020 Order, as amended December 16, 2020, this Appeal was scheduled to be heard via WebEx on January 27, 2021 to accommodate both the pro se Appellant and Respondent. As a result, the Court needs the Appellant's contact information to invite Appellant's participation in the WebEx hearing. After multiple attempts the Court was unable to obtain this information prior to the hearing. However, the Clerk of Court sent notice of the proceedings with the virtual courtroom instructions to Appellant's last known address on December 17, 2020. Moreover, the Appellant's phone number of record is disconnected and no longer in service. Respondent's information was obtained and he availed himself of the WebEx proceedings until such time that it was clear that the Appellant had not made

ORDER INFORMATION

This order ends does not end the case. See Page 2 for additional information.

For Clerk of Court Office Use Only

This judgment was electronically entered by the Clerk of Court as reflected on the Electronic Time Stamp, and a copy mailed first class to any party not proceeding in the Electronic Filing System on 01/28/2021 .

Danny D H
Case Party Info Protected
Magnus E Shier, III for Magnus E Shier, III
Danny D Henrickson for Danny D Henrickson
Danny D Henrickson for Danny D Henrickson
Magnus E Shier, III for Magnus E Shier, III

NAMES OF TRADITIONAL FILERS SERVED BY MAIL

Court Reporter:

E-Filing Note: The date of Entry of Judgment is the same date as reflected on the Electronic File Stamp and the clerk's entering of the date of judgment above is not required in those counties. The clerk will mail a copy of the judgment to parties who are not E-Filers or who are appearing pro se. See Rule 77(d), SCRPC.

any attempts to participate. Accordingly, pursuant to S.C. Code Ann. 18-7-170, the Appeal is dismissed for failure to prosecute. See also *McComas v. Ross*, 368 S.C. 59, 62, 626 S.E.2d 902, 904 (Ct. App. 2006). The Appellant shall have ten (10) days from receipt of this Order to challenge the relief contained in this Order.



Charleston Common Pleas

Case Caption: Magnus E Shier III VS Danny D Henrickson , defendant, et al

Case Number: 2020CP1005405

Type: Order/Electronic Form 4

IT IS SO ORDERED.

s/D.L. Jefferson Ninth Judicial Circuit Judge 2128

STATE OF SOUTH CAROLINA)
COUNTY OF CHARLESTON)
))
))
DANNY D HENRIKSEN)
))
Plaintiff- Respondent)
))
-versus-)
))
MAGNUS SHIER)
))
Defendant- Appellant)
))
))

IN THE SMALL CLAIMS COURT
CASE NO: 2020CV1011501116
COMMON PLEAS: 2020-CP-10-5405

RETURN

FILED
2021 JAN -6 AM 10:16
JULIE JAMES
CLERK OF COURT
CHARLESTON
JAN 06 2021
SMALL CLAIMS COURT

THIS is an appeal from the Charleston County Small Claims Court, North Charleston Division.

The lower court has never been served by the appellant with the appeal. The case originated on August 3, 2020 with the complaint by the plaintiff alleging the failure by the defendant to complete cabinet work.

The court issued the noticed of non service on August 13, 2020 noting the address provided as a vacant lot.

Subsequently, the court received a written request to achieve service by publication noting the due diligence exercised by the plaintiff including but not limited to securing the services of a private investigator who was also unsuccessful at service of the summons and complaint.

The court granted the motion for publication. The summons and complaint were published in a local newspaper of general circulation on two dates in September and one in October as evidence by the paid receipt.

A default was entered based upon the failure to file an answer and a damages hearing scheduled by a letter of November 5, 2020 sent to the last known address. The letter was not returned by the postal service to the court.

A damages hearing was conducted on November 20, 2020 and a written transcript of judgment issued on that same day.

The court utilized and mailed all correspondence to the same address written on the appeal form by the defendant.

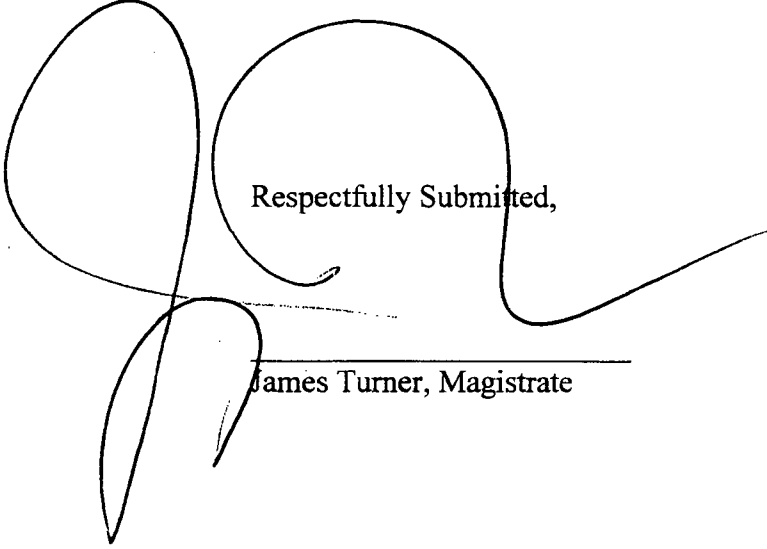
A large, stylized handwritten signature in black ink, consisting of several loops and a long horizontal tail.

Respectfully Submitted,

James Turner, Magistrate

J
North Charleston, South Carolina
January 7, 2021



NORTH AREA SMALL CLAIMS COURT
4045 BRIDGE VIEW DRIVE
NORTH CHARLESTON, SC 29405

Return Service Requested

Magnus Shier DBA Edgewater Kitchens
1954 Dulsey Rd.
Charleston, SC 29407



NORTH AREA SMALL CLAIMS COURT
4045 BRIDGE VIEW DRIVE
NORTH CHARLESTON, SC 29405

Return Service Requested

Danny D. Henriksen
322 Cabell St.
Charleston, SC 29407

STATE OF SOUTH CAROLINA

)
)
)
)
)
)

2020CV1011501116
CIVIL CASE NUMBER

COUNTY OF CHARLESTON

IN THE MAGISTRATE'S COURT

SUMMONS

Danny D Henriksen
322 Cabell St.
Charleston, SC 29407
(509) 947-7354

PLAINTIFF(S)

Vs

Magnus Shier Dba
Edgewater Kitchens
1954 Dulsey Rd.
Charleston, SC 29407

DEFENDANT(S)

TO THE DEFENDANT(S) NAMED ABOVE:

YOU ARE SUMMONED and required to answer the allegations of the attached complaint and present any appropriate counterclaims/crossclaims to the attached Complaint within THIRTY days from the first day after receipt of this summons. Your Answer must be received by the:

Small Claims - North
4045 Bridge View Drive
P. O. Box 70235
North Charleston, SC 29405
Phone: (843) 202-6650
Fax: (843) 202-6652

If you fail to answer within the prescribed time, a judgment by default may be rendered against you for the amount or other remedy requested in the attached complaint, plus interest and costs. **If you desire a jury trial, you must request one in writing at least five (5) working days prior to the date set for trial.** If no jury trial is timely requested, the matter will be heard and decided by the Judge.

READ ATTACHED INSTRUCTIONS CAREFULLY

August 5, 2020

20200115 0116

Case No:
Filed:
Served:
Default:
Hearing:

FILED IN
CHARLESTON COUNTY
AUG 03 2020
NORTH AREA
SMALL CLAIMS COURT

STATE OF SOUTH CAROLINA
COUNTY OF CHARLESTON

IN THE SMALL CLAIMS COURT

DANNY D. HENRIKSEN
Plaintiff
322 CABELL ST.
Street Address
CHARLESTON S.C. 29407
City State Zip
509 947 7354
Phone

Edge WATER Kitchens
Defendant MAGNUS SHIER DBA.
1954 DULSEY Rd.
Street Address
CHARLESTON S.C. 29405
City State Zip
843 225 6263
Phone

I, the plaintiff in this civil action, make the following claim against the defendant:

- 1.) I believe that the defendant is a resident of _____.
- 2.) Check a, b, or c to indicate the type of suit and supply documents required.
 - a. () This is a suit on a note; Two (2) copies of note attached. Defendant has defaulted in payment of said note with balance of \$ _____ now due and payable.
 - b. () This is a suit on an account; Two (2) copies of statement attached. Sign as affiant swearing to statement and have your signature notarized.

SWORN and subscribed before me this
_____ day of _____ 20 _____

Attached to this complaint is a statement of account which I swear to be true and correct, with no part of the balance having been paid.

NOTARY PUBLIC, State of South Carolina
My Commission Expires: _____

Affiant=s Signature (Plaintiff)

c. (X) OTHER. This is a claim based on the following facts: (Describe Complaint)
See ATTACHED

(attach supplement if necessary)

3.) I believe because of the following information, that I am entitled to, and request a judgment for
\$ 7262.00 and/or other relief:

(Include any costs resulting from this action. (Example: court costs, legal fees, interest)

I STATE UNDER PENALTY OF PERJURY THAT THE ABOVE IS CORRECT AND TRUTHFUL.

8/3/2020
Date

Danny D. Henrikson
Signature of Plaintiff or Attorney

EDGEWATER KITCHENS COMPLAINT

Contractor did not complete work on cabinets in a timely manner.

Did not tile the backsplash per drawings

Did not install cabinet glass doors on the north wall.

Did not finish the corner pantry installation.

Did not finish the Island trim or install cabinet door.

Contractor did extort payments to install the final cabinet.

Edgewater kitchens entered into a contract, to complete my kitchen on 9/26/19 with the exceptions of appliances, electrical, and plumbing. The project according to them would take approximately four weeks. They were to install the cabinets, Island, corner pantry, complete the backsplash, install the counter tops per the agreed drawings and artistic designs.

During the negotiations of the contract, we discussed in length what was to be done. We discussed the tiling of backsplash with subway tile and the corner pantry. The cabinet glass doors were the last addition to the contract.

They had told me were to go to look at designs of tile and countertops. The initial price of the work was 25,500.00. When the backsplash was added the price was 29119.84. The cabinet glass windows on the north wall was, the last item which raised the price to 31,509.84.

Into the renovations on the sixth week, problems with working relations started when the contractor presented on 1/17/20 addendum prices for so called additional work, without any prior approval. The figures were wrote on a piece of cardboard, \$1000.00 for administration fees for counter top installation, \$1000.00 for sheetrock work, \$1100.00 for floor molding. I told him that we had discussed that before we entered into the contract and it was included. That is when he wanted to see the contract I was talking about.

The Contractor basically held the kitchen unusable for 8 weeks. He used saws, planners, and sanders in the house without catch bags attached. Although it is

sometimes necessary to use these tools inside the house, most of the time it is not. I asked that he not use the saw inside the house unless necessary after the counter tops were installed, he did so anyway. He reduced his hours from 30 per week, to about 20 prolonging the job while continuing to create a mess inside the house and creating a hazardous environment for the occupants of the house. After 8 weeks, on January 30th, my son and I removed his tools from the kitchen and notified him to pick them up.

On February 1st meeting at Edgewater Kitchens office. Paid \$2850 to get last or extortion cabinet installed. On 2/3/20202 he started installing the last cabinet.

Please see attachments

1. Contract signed by Magnus Shier
2. Financial figures for complaint.
3. Time line for contract.
4. Text messages for time of contract.
5. Pictures of kitchen, living room and bedroom during remodeling of kitchen.

Contract for Kitchen remodel

322 Cabell St, Charleston S.C.

- (1. Remove existing cabinets.) Habitat
2. Build corner Walled pantry per Drawings.
 3. Install new cabinets and island per design Layout.
Placement of island to be determined in field.
 4. Install crown molding and lower molding, and finish cabinets.
 5. Install counter tops, backsplash, and mount sinks.
 6. Install floor moldings as needed.
 7. Contractor to provide labor and material as needed.
 8. Owner will provide, sinks, plumbing fixtures, mixing valves, cabinet hardware, electrical wiring, receptacles, and appliances. No plumbing, electrical or HVAC work is included in this contract.

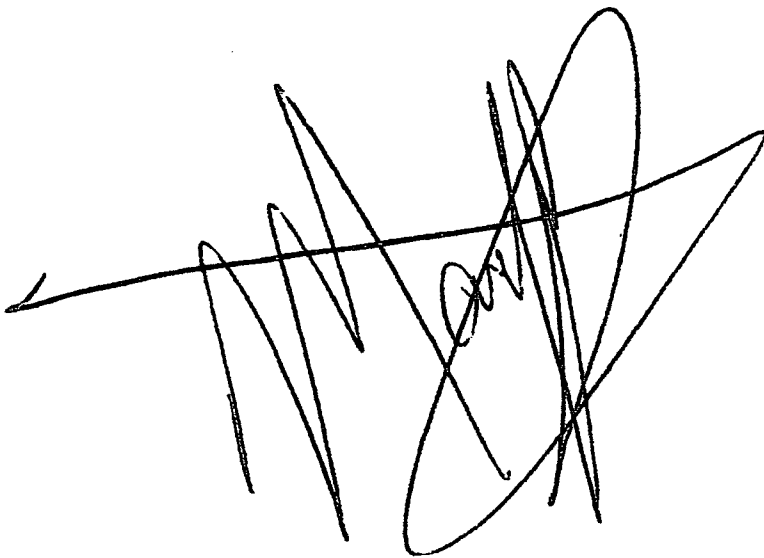
A large, stylized handwritten signature in black ink, consisting of several overlapping loops and sharp points, positioned at the bottom of the page.

00

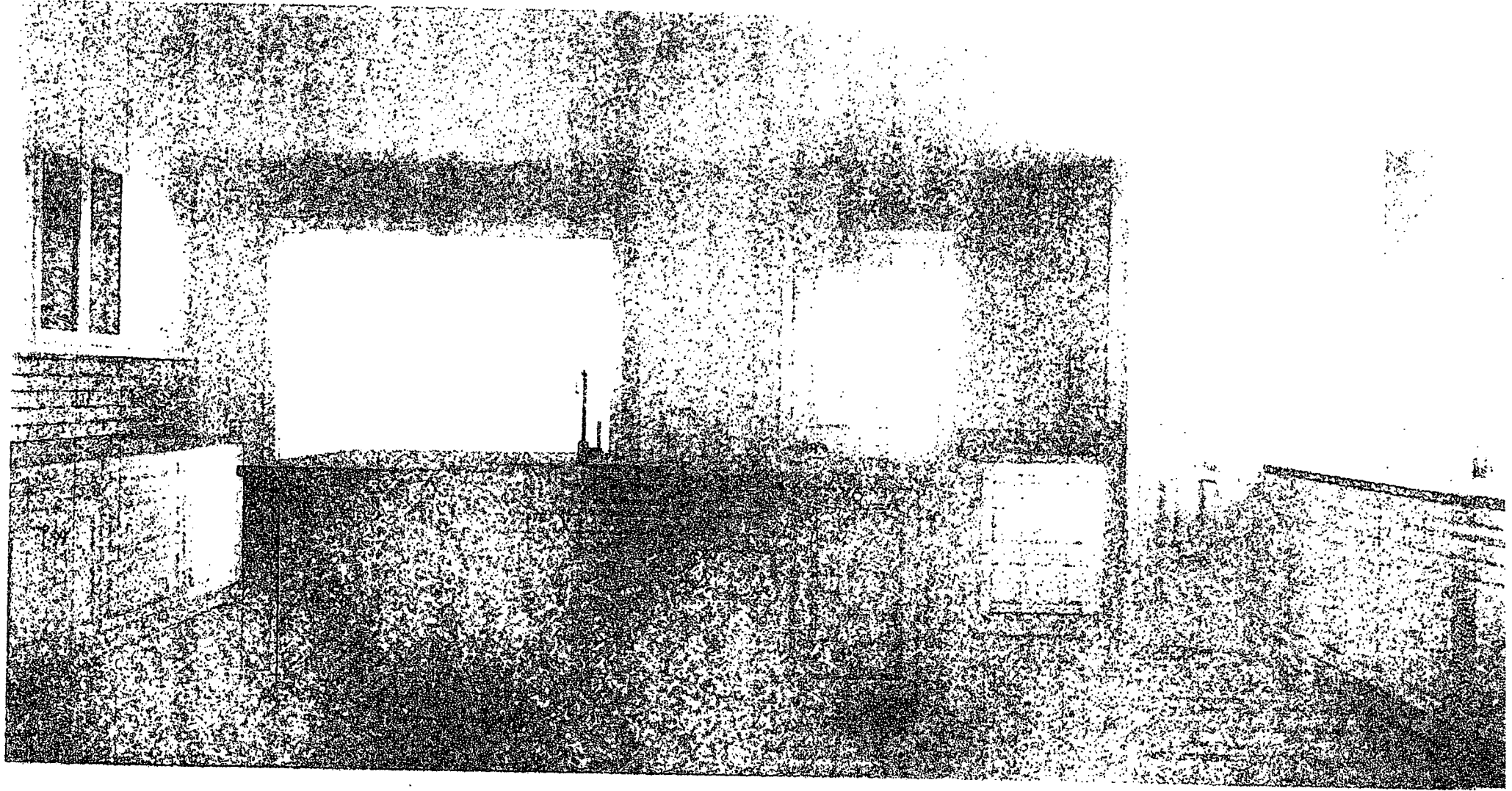

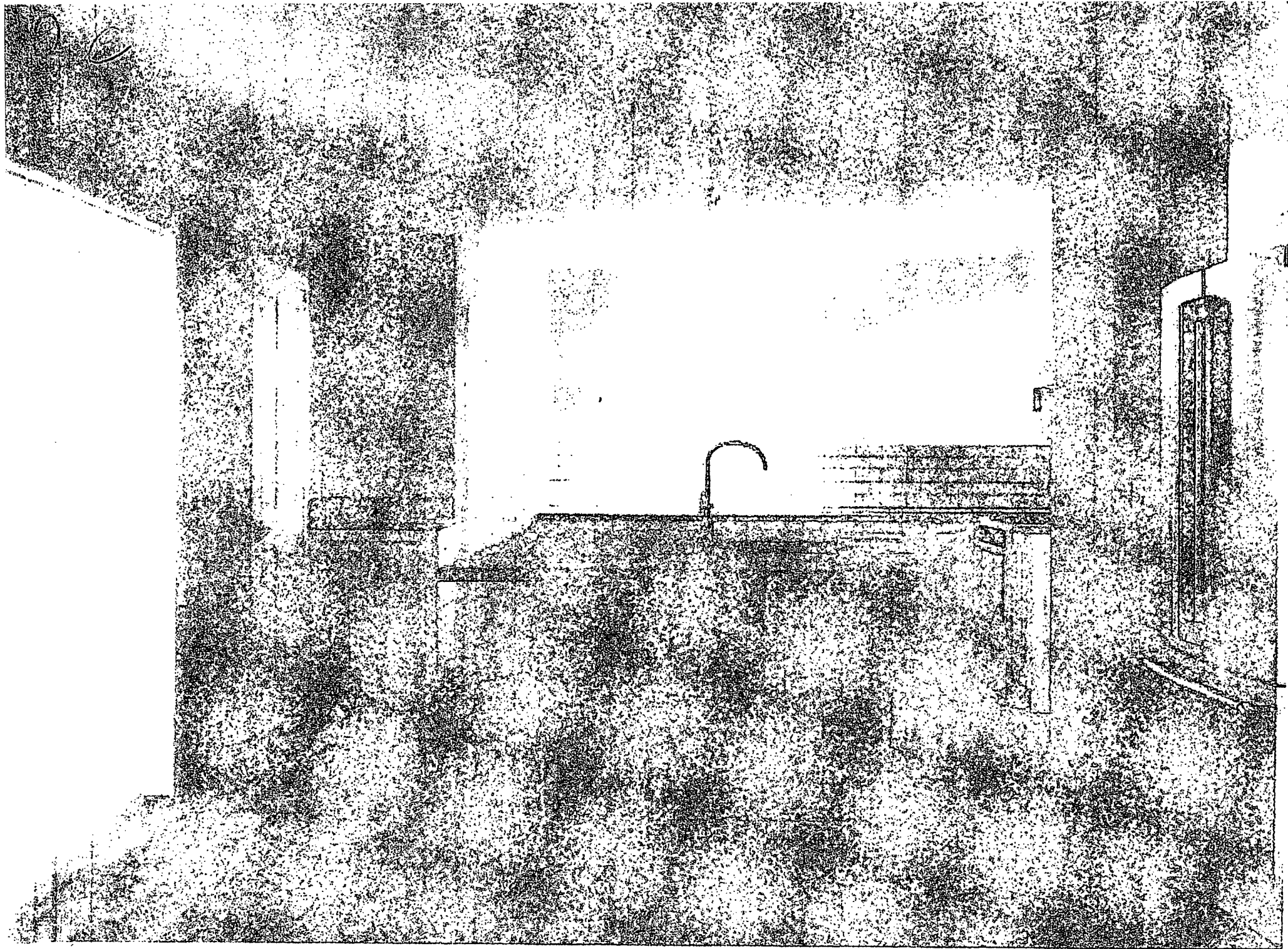

2

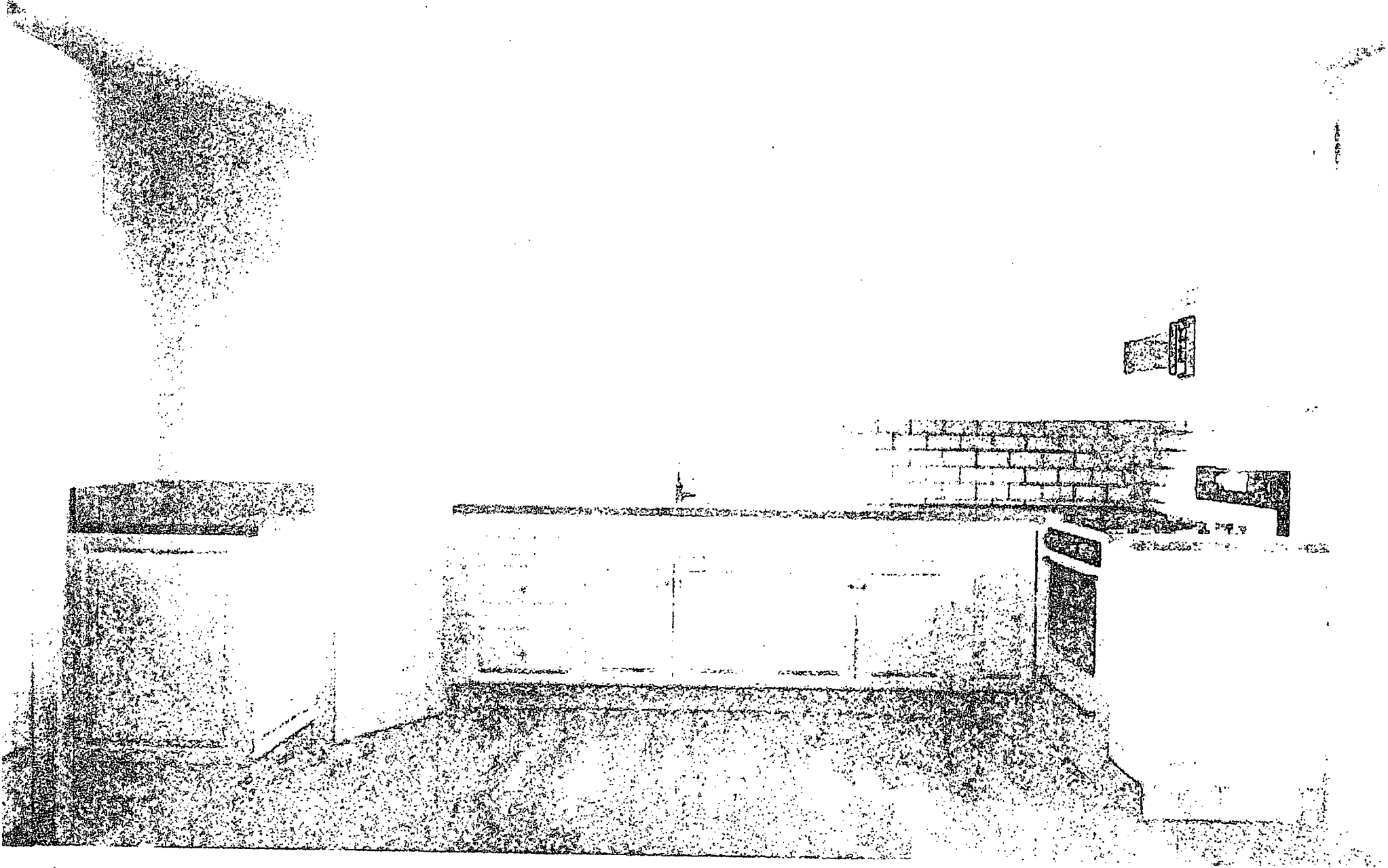

7

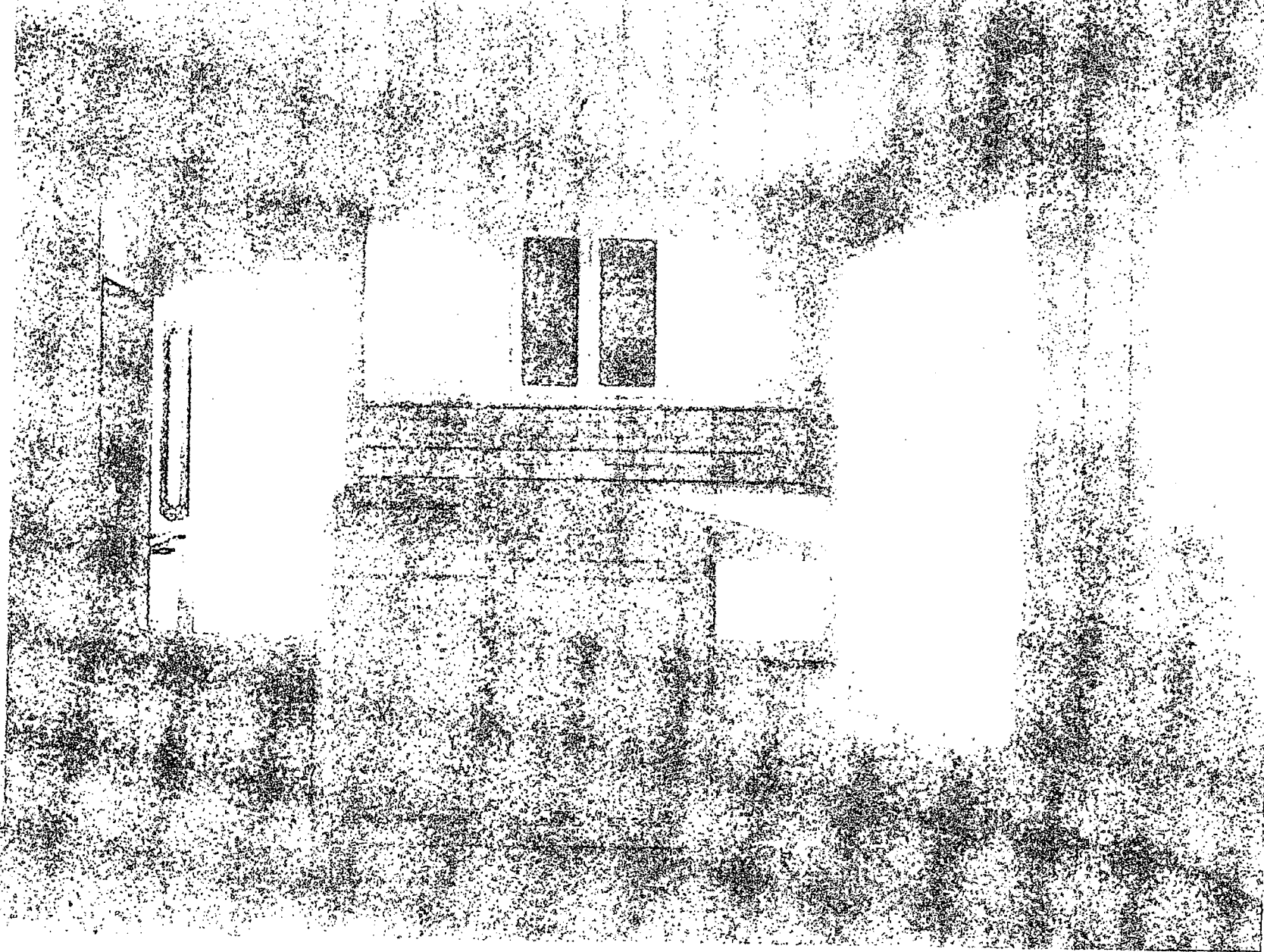

C

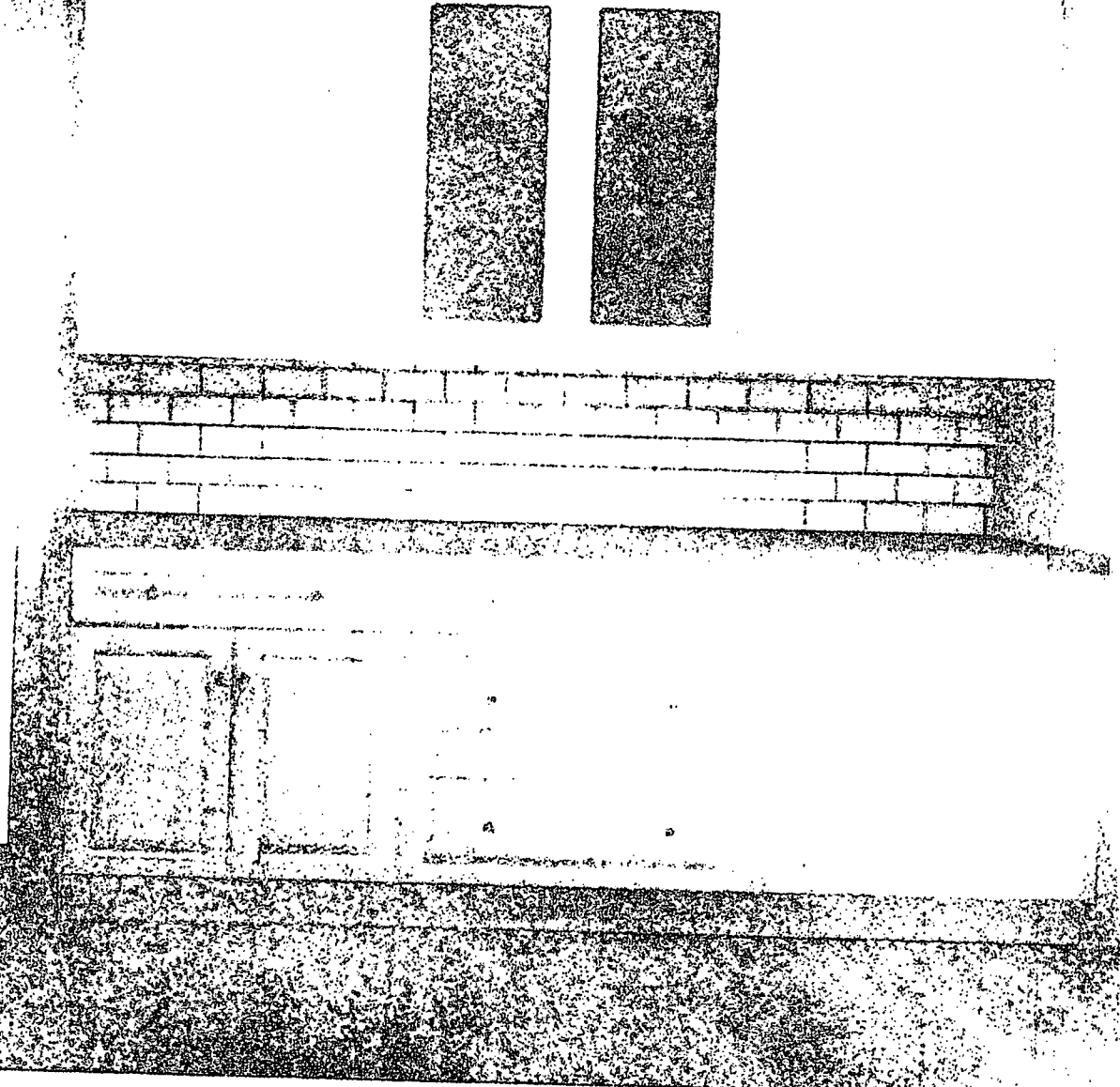
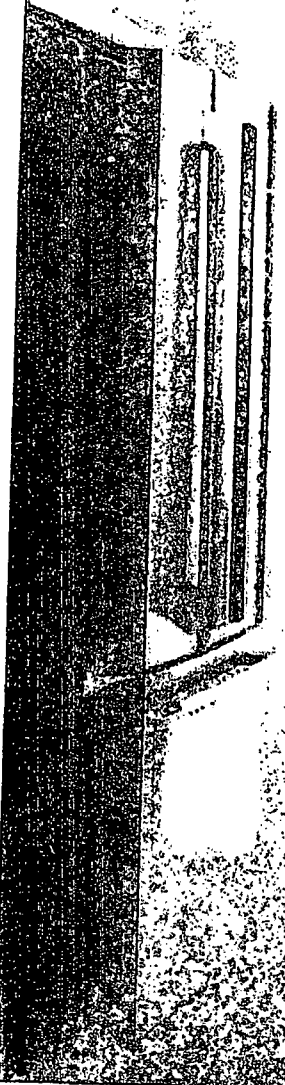

Copy

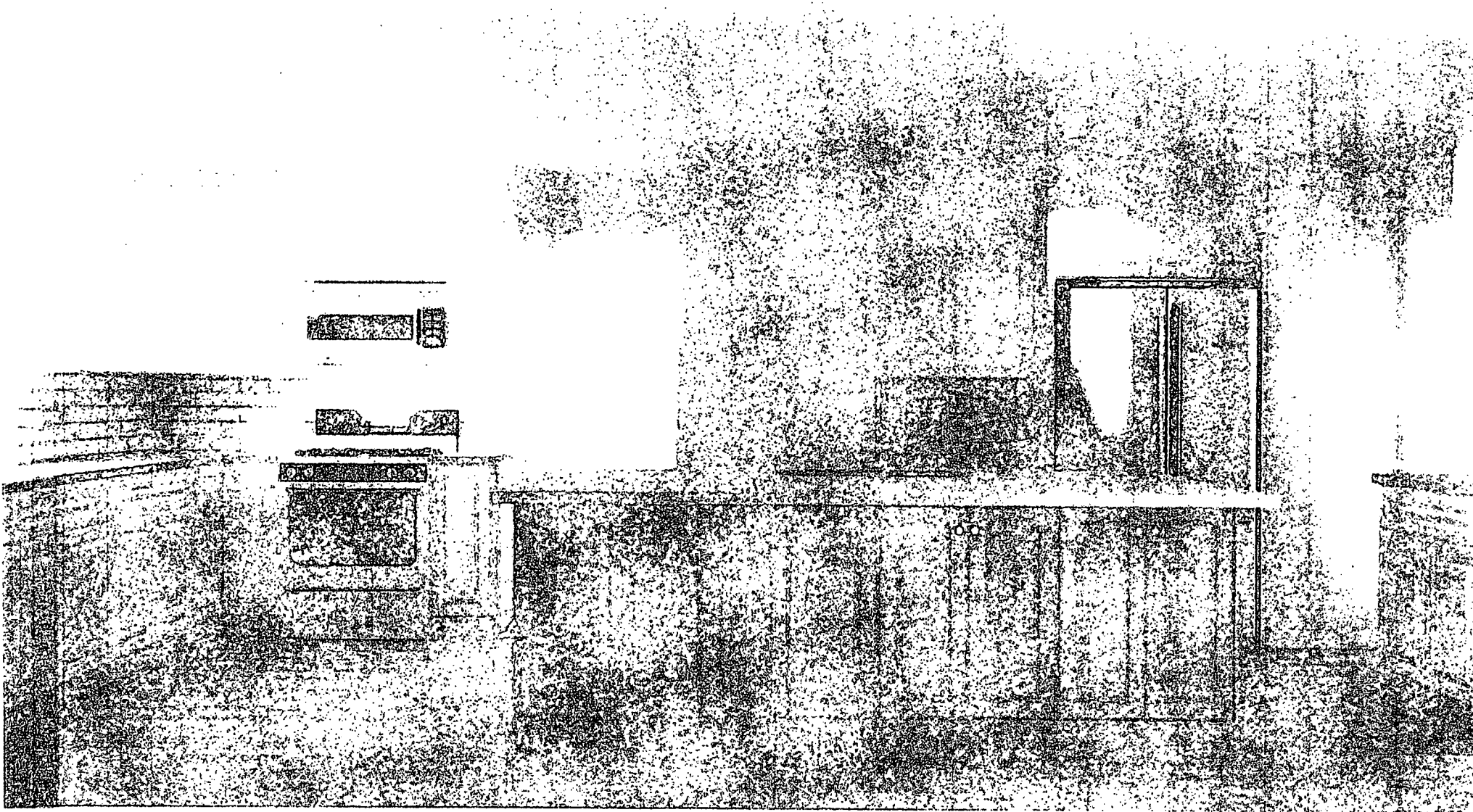

Time Line 322 Cabell Kitchen

- 08/20/19 Paid \$300.00 for initial consultation and work scope verification. This fee was to be deducted from contract price if awarded.
- 09/26/19 Entered into contract Paid \$19,119.84 was told that kitchen would be complete in four weeks, except for appliances, electrical, and plumbing.
- 12/02/19 Work started, completed tear out in one day. Project to be 4 to 5 weeks.
- 12/27/19 Payment of \$6,657.00 noticed work was going slow.
- 01/07/20 Moved appliance delivery from 01/13/20 to 01/27/20.
- 01/17/20 Without any prior consent, presented an invoice for additional work, for sheetrock work, administrative fee, and floor moldings amount of \$3100.00. I informed him that the work was covered under the original contract.
- 01/20/20 Argument over what was covered under the intial contract. He said the backsplash tile work was not covered under contract.
- 01/22/20 Moved appliance delivery from 01/27/20 to 02/10/20.
- 01/23/20 Counter tops were installed by Palmetto surfacing and sinks were installed they asked if I wanted the four inch counter top backing, I said yes. Magnus said he needed another payment.
- 01/24/20 Paid Magnus \$1733.00, he said he needed more than that, and he wanted to see the contract I was talking about. He followed me to my dad's house on 2222 Longview Court, and showed him the contract which he had signed. I knew at this time I would have to take him to court, Kitchen still progressing very slow and late.

01/28/20 Another argument in the meeting, Magnus wanting more money. No work performed. Palmetto Surfacing came and installed last piece of counter top backing behind stove.

01/29/20 Worked 2 hours. Called and asked when the last cabinet would be installed he said whenever he got paid.

01/30/20 Jacob and myself moved all of Magnus tools and equipment out of the house and started cleaning up.

02/01/20 Meeting at Edgewater kitchens office, told Magnus there would be no more using saw inside the house, and he had one week to finish the job. Paid \$2850 to get last or extortion cabinet installed.

02/03/20 Installed the extortion cabinet in the afternoon.

02/04/20 Installed bottom trim on extortion cabinet. Informed me that the trash can pull out drawer would not be shipped until February 28.

02/05/20 No show

02/06/20 Installed trim around window and floor molding on closet.

02/07/20 Met Magnus and Pat O'Neil house told Pat to bring her camera if she wanted to take pictures of their work. Met at 3 PM Paid \$1000. Island trim not finished, door on garbage cabinet not installed, Pantry closet not finished, glass doors on cabinet not installed, and backsplash not tiled.

04/16/20 Pat O'Neil called and asked if Magnus could come and finish the job. I told her I would have to contact my sons. My sons and I decided it would be better not to let him return to finish work.

04/22/20 Called Magnus Shier asked if I could have cabinet door to install on the garbage cabinet, he said I still owed him \$500.00 on the contract and I could have the door once I paid him.

04/29/20

Pat O'Neil called again asking Magnus and I have a meeting. I told her I was not interested in having a meeting.

05/15/20

Pat O'Neil called and said I could have the cabinet door.

STATE OF SOUTH CAROLINA)
COUNTY OF CHARLESTON)

2020CV1011501116
CIVIL CASE NUMBER
IN THE MAGISTRATE'S COURT
AFFIDAVIT OF SERVICE

Vacant Lot 7-Aug
26

Danny D Henriksen
322 Cabell St.
Charleston, SC 29407
(509) 947-7354

PLAINTIFF(S)

Vs

Magnus Shier Dba Edgewater Kitchens
1954 Dulsey Rd.
Charleston, SC 29407

DEFENDANT(S)

1956 Dulsey Rd.
← VACANT →
Up for Rent

PERSONALLY PREPARED BEFORE ME, the undersigned deponent, who being duly sworn
says that (s)he served the _____ in this action

(Describe document(s) served)

on _____ by delivery to
(Name of party served)

_____ personally;
(Name of party served)

_____ the _____ of the party served,
(Name of person served) (Note relationship to party)

and a person of discretion residing at the residence of the party served;

_____ the _____ of _____
(Name of person served) (Title) (Name of corporate party served)

and leaving with (him) (her) a copy at _____
(Street address)

in _____ County, South Carolina,
(City or Town) _____ County

on _____ at _____ o'clock

that deponent knows the person so served, and that deponent is not a party of this action, is not less than eighteen (18) years of age and has no interest therein or connection therewith.

Unable to locate and serve the above process on the defendant after diligent efforts to do so. The process is returned unexecuted.

Sworn to and Subscribed before me)
this _____ day of _____, 20 _____)
) _____)
) Signature of Deponent)

Notary Public for South Carolina) Entered in the Sheriff's Service Book on _____
My Commission expires _____) Book _____ Page _____ Number _____

Return to:
Small Claims - North
4045 Bridge View Drive
P. O. Box 70235
North Charleston, SC 29405
Phone: (843) 202-6650
Fax: (843) 202-6652

Date 9/10/2020

Small Claims-North

Judge : James A Turner

4045 Bridge View Drive

North Charleston, SC 29405

FILED IN
CHARLESTON COUNTY
SEP 09 2020
NORTH AREA
SMALL CLAIMS COURT

Your Honor

I, Danny Henriksen, have filed a claim in small claims court case number 2020CV1011501116, Reference # 1005. The court has tried to serve the defendant Edgewater kitchens, Magnus Shier to no avail. I have hired a private process server Jake Brunson who has tried five times to serve Mr. Shier with no success. I am requesting permission from the court to publish the serving notice in the Newspaper.

If permission is granted please inform me of the required information to be posted in the notice.

Thank you,



Danny D Henriksen

322 Cabell St.

Charleston SC 29407

Ph. 5099477354

Motion
Served
9/13/2020

~~DeHenriksen~~

~~DDHenri70@hotmail.com~~

DDHenri70@hotmail.com

STATE OF SOUTH CAROLINA)
COUNTY OF CHARLESTON)

2020CV1011501116
CIVIL CASE NUMBER
IN THE MAGISTRATE'S COURT
AFFIDAVIT OF SERVICE

Danny D Henriksen
322 Cabell St.
Charleston, SC 29407
(509) 947-7354

PLAINTIFF(S)

Vs

Magnus Shier Dba Edgewater Kitchens
1956 Dulsey Rd.
Charleston, SC 29407

DEFENDANT(S)

FILED IN
CHARLESTON COUNTY
SEP 21 2020
NORTH AREA
SMALL CLAIMS COURT

PERSONALLY PREPARED BEFORE ME, the undersigned deponent, who being duly sworn
says that (s)he served the _____ in this action

(Describe document(s) served)

on _____ by delivery to
(Name of party served)

_____ personally;
(Name of party served)

_____ the _____ of the party served,
(Name of person served) (Note relationship to party)

and a person of discretion residing at the residence of the party served;

_____ the _____ of _____
(Name of person served) (Title) (Name of corporate party served)

and leaving with (him) (her) a copy at _____
(Street address)

in _____ County, South Carolina,
(City or Town) County

on _____ at _____ o'clock

that deponent knows the person so served, and that deponent is not a party of this action, is not less than eighteen (18) years of age and has no interest therein or connection therewith.

Unable to locate and serve the above process on the defendant after diligent efforts to do so. The process is returned unexecuted.

Sworn to and Subscribed before me
this 23 day of Oct, 2020

Courtney Powell

[Signature]

Signature of Deponent

Notary Public for South Carolina

My Commission expires

10/30/2029

) Entered in the Sheriff's Service Book on _____
) Book _____ Page _____ Number _____

Return to:

Small Claims - North
4045 Bridge View Drive
P. O. Box 70235
North Charleston, SC 29405
Phone: (843) 202-6650
Fax: (843) 202-6652

Courtney Powell
Notary Public, State of South Carolina
My Commission Expires 10/30/2029

2487 Ash River #D

Danny D Henriksen
322 Cabell St.
Charleston, SC 29407
(509) 947-7354

PLAINTIFF(S)

Vs

Magnus Shier Dba Edgewater Kitchens
1956 Dulsey Rd.
Charleston, SC 29407

DEFENDANT(S)

FILED IN
CHARLESTON COUNTY
SEP 21 2020
NORTH AREA
SMALL CLAIMS COURT

PERSONALLY PREPARED BEFORE ME, the undersigned deponent, who being duly sworn
says that (s)he served the _____ in this action
(Describe document(s) served)

on _____ by delivery to
(Name of party served)

_____ personally;
(Name of party served)

_____ the _____ of the party served,
(Name of person served) (Note relationship to party)

and a person of discretion residing at the residence of the party served;

_____ the _____ of _____
(Name of person served) (Title) (Name of corporate party served)

and leaving with (him) (her) a copy at _____
(Street address)

in _____ County, South Carolina,
(City or Town) _____ County

on _____ at _____ o'clock

that deponent knows the person so served, and that deponent is not a party of this action, is not less than eighteen (18) years of age and has no interest therein or connection therewith.

Unable to locate and serve the above process on the defendant after diligent efforts to do so. The process is returned unexecuted.

Sworn to and Subscribed before me)
this _____ day of _____, 20 _____)
) _____ Signature of Deponent
)
)

Notary Public for South Carolina) Entered in the Sheriff's Service Book on _____
My Commission expires _____) Book _____ Page _____ Number _____

Return to:
Small Claims - North
4045 Bridge View Drive
P. O. Box 70235
North Charleston, SC 29405
Phone: (843) 202-6650
Fax: (843) 202-6652

2487 Ash River #D

STATE OF SOUTH CAROLINA
COUNTY OF CHARLESTON

Danny D Henriksen
322 Cabell St.
Charleston, SC 29407

FILED IN
CHARLESTON COUNTY
AUG 13 2020
NORTH AREA
SMALL CLAIMS COURT

NOTIFICATION OF NON-SERVICE

RE: Danny D Henriksen

Vs Magnus Shier Dba Edgewater Kitchens

PLAINTIFF(S)

DEFENDANT(S)

CASE NUMBER: 2020CV1011501116

Please be advised that your civil action has been returned from the Charleston County Sheriff's Department/Constable/Process Server with non-service for the following reason(s):

- Defendant does not reside in Charleston County
- Defendant no longer resides at given address
- Defendant is deceased
- Defendant's address is unknown
- Vacant Lot**
- Apartment number or lot number required
- Defendant never home
- Unable to serve after five or more attempts
- Restraining Orders - There is NOT a fee of \$10 to attempt service at a new address.
- Other: _____

1956 Dulsey Rd.

Please note that **the Court must receive any new address within 30 days** from the date of this letter with a fee of \$10 to attempt service at the new address. Should no new address be supplied within the number of days stated above, this action will be dismissed and you will be required to re-file for further action. Please submit any new information to the below address or fax to the number shown.

Small Claims - North
4045 Bridge View Drive
P. O. Box 70235
North Charleston, SC 29405
Phone: (843) 202-6650
Fax: (843) 202-6652
August 13, 2020



City Paper Publishing, LLC
 1316 Rutledge Ave.
 Charleston, SC 29403
 (843) 577-5304 x127

Peril

Invoice
 Invoice # 154183
 Invoice Date: 9/15/2020
 Terms: Net 30
 Rep: CT

Bill to: Bill to ID: 33888

Danny Henriksen
 322 Cabell St.
 Charleston, SC 29407

Sold to: Account ID: 33888

Danny Henriksen

FILED IN
 CHARLESTON COUNTY
 OCT 27 2020
 NORTH AREA
 SMALL CLAIMS COURT

Ad Insertions included in this Invoice

Date	Type	Description	Charge	Disc	Applied	Total
9/23/20	Sale	Ad PO: Legal Notice Market: 1x6"	\$72.00			\$72.00
9/30/20	Sale	Ad PO: Legal Notice Market: 1x6"	\$72.00			\$72.00
10/7/20	Sale	Ad PO: Legal Notice Market: 1x6"	\$72.00			\$72.00
9/28/20	Pmt Applied	Ck #995009			-\$72.00	
9/28/20	Pmt Applied	Ck #995009			-\$72.00	
9/28/20	Pmt Applied	Ck #995009			-\$72.00	

Items: 6

Please make check payable to Charleston City Paper Thanks for your business!	Total Charges	\$216.00
	Discount	
	Payments Applied	-\$216.00
	Total Balance Due by 10/15/2020	\$0.00

Please return this portion with your payment. **Advertising Invoice**

Invoice Date: 9/15/2020
 Invoice # 154183
 Account # 33888

Amount Enclosed _____

Remit Payment to:
 Charleston City Paper
 1316 Rutledge Ave.
 Charleston, SC 29403

Advertising
Total Balance Due by 10/15/2020 **\$0.00**



1316 Rutledge Ave.
Charleston, SC 29403
www.charlestoncitypaper.com

AFFIDAVIT

This letter is to serve notice that the Charleston City Paper, a paper of general circulation and of record, has run the following public notice for: Danny Henriksen on the following dates: 9/23/20, 9/30/20 & 10/07/20. The notice ran as follows:

STATE OF SOUTH CAROLINA
COUNTY OF CHARLESTON
IN THE MAGISTRATE'S COURT
CIVIL CASE NUMBER
2020CV101501116
Danny D Henriksen
322 Cabell St.
Charleston, SC 29407
(509) 947.7354
PLAINTIFF(S)
Vs
Magnus Shier
DBa Edgewater Kitchens
1934 Dufsey Rd.
Charleston, SC 29407
DEFENDANT(S)
SUMMONS
TO THE DEFENDANT(S) NAMED
ABOVE:
YOU ARE SUMMONED and
required to answer the allega-
tions of the attached complaint
and present any appropriate
counterclaims/crossclaims to
the attached Complaint within
THIRTY days from the first day
after receipt of this summons.
Your Answer must be received
by the:
Small Claims
North 4045 Bridge View Drive
P. O. Box 70235
North Charleston, SC 29405
Phone: (843) 202-6650
Fax: (843) 202-6652
If you fail to answer
within the prescribed time,
a judgment by default may
be rendered against you for
the amount or other remedy
requested in the attached com-
plaint, plus interest and costs.
If you desire a jury trial, you
must request one in writing
at least five (5) working days
prior to the date set for trial. If
no jury trial is timely requested,
the matter will be heard and
decided by the Judge.
August 5, 2020
MVID SCCN700
(Amended 12/2015)

Advertising Clerk

Subscribed and sworn to before me this
9th day of October
A.D. 2020

NOTARY PUBLIC, SC
My commission expires

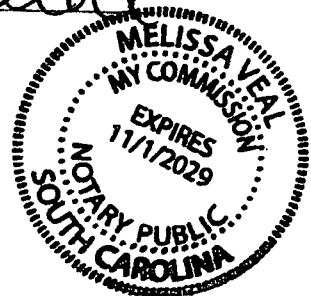

Estate of:
PETER WILLIAM MEHLMAN
 2020-ES-10-1149
 DOD: 07/24/20
 Pers. Rep:
BERNICE L. MEHLMAN
 1040 HILLS PLANTATION DR.
 CHARLESTON, SC 29412
 Any:
UDYIA P. DAVIDSON, ESQ.
 9 STATE ST.
 CHARLESTON, SC 29401

Estate of:
RICHARD ELLIOTT BARHAM
 2020-ES-10-1154
 DOD: 07/13/20
 Pers. Rep:
JOHN CLIFTON BARHAM
 37 LORD CALVERT DR.
 CHARLESTON, SC 29407

Estate of:
PATRICIA ALBERTHA RICHARDSON-SCOTT
 2020-ES-10-1166
 DOD: 07/18/20
 Pers. Rep:
PATRICIA M. RICHARDSON-SCOTT
 2346 KENTON ST.
 CINCINNATI, OH 45206

Estate of:
PAUL MICHAEL KUCHAR
 2020-ES-10-1173
 DOD: 07/29/20
 Pers. Rep:
MARK KUCHAR
 610 RUE SAINT LA ROUSE
 CHESAPEAKE, VA 23320

Any:
GORDON H. GARRETT, ESQ.
 1075 E. MONTAGUE AVE.
 NO. CHARLESTON, SC 29405

Estate of:
ISAH DRAIN
 2020-ES-10-1197
 DOD: 07/26/20
 Pers. Rep:
WILHEMENA DRAIN
 8353 WYSELL ST.
 NO. CHARLESTON, SC 29406

Estate of:
SYLVIA HARLEY MACDONALD
 2020-ES-10-1216
 DOD: 06/23/20
 Pers. Rep:
MARGARET TALITHA HARLEY CRAWLEY
 3910 WILLOW POINTE LN.
 JOHNS ISLAND, SC 29455

STATE OF SOUTH CAROLINA COUNTY OF CHARLESTON IN THE FAMILY COURT FOR THE NINTH JUDICIAL CIRCUIT DOCKET NO: 2020-DR-10-1053

SOUTH CAROLINA DEPARTMENT OF SOCIAL SERVICES

VERSUS

Natassja Robinson et al.

NOTICE

TO ALL INTERESTED PARTIES: You are hereby summoned and required to answer the Complaint in this action filed with the Clerk of Court for Charleston County on April 20, 2020. Upon proof of interest, a copy of the Complaint will be delivered to you upon request from the Clerk of Court in Charleston, and you must serve a copy of your Answer to the Complaint on the Plaintiff, the Charleston County Department of Social Services, at the office of their Attorney, Sally R. Young of the Charleston County Department of Social Services, 3366 Rivers Ave. N. Charleston, South Carolina 29405-5714, within thirty days of this publication. If you fail to answer within the time set forth above, the Plaintiff will proceed to seek relief from the Court.

STATE OF SOUTH CAROLINA COUNTY OF CHARLESTON IN THE NINTH JUDICIAL CIRCUIT CIVIL CASE NUMBER 2020CV101501116

Danny D. Henriksen
 322 Cabell St.
 Charleston, SC 29407
 (509) 947.7354
 PLAINTIFF(S)

vs.

Magnus Shier
 Dba Edgewater Kitchens
 1954 Dulsey Rd.
 Charleston, SC 29407
 DEFENDANT(S)

SUMMONS

TO THE DEFENDANT(S) NAMED ABOVE: YOU ARE SUMMONED and required to answer the allegations of the attached complaint and present any appropriate counterclaims or claims to the attached Complaint within THIRTY days from the first day after receipt of this summons. Your Answer must be received by the:

Small Claims
 North 4045 Bridge View Drive
 P. O. Box 70235
 North Charleston, SC 29405
 Phone: (843) 302-6650
 Fax: (843) 202-6652

If you fail to answer within the prescribed time, a judgment by default may be rendered against you for the amount or other remedy requested in the attached complaint, plus interest and costs. If you desire a jury trial, you must request one in writing at least five (5) working days prior to the date set for trial. If a jury trial is timely requested, the matter will be heard and decided by the Judge.

August 5, 2020
 MVJB SCCN700
 (Amended 12/2015)

STATE OF SOUTH CAROLINA COUNTY OF CHARLESTON IN THE COURT OF COMMON PLEAS FOR THE NINTH JUDICIAL CIRCUIT CASE NO: 2019-CP-10-03589

JESSICA MEANS AND HALL & NEASE, LLC
 PETITIONERS,
 VS.
 DONALD B. MCCUTCHEON,
 RESPONDENT

SUMMONS

TO THE DEFENDANT ABOVE NAMED: YOU ARE HEREBY SUMMONED AND REQUIRED TO RESPOND TO THE ORDER OF REFERENCE AND RULE TO SHOW CAUSE FILED WITH THE CHARLESTON COUNTY CLERK OF COURT ON FEBRUARY 25, 2020 AND TO PROVIDE THE DOCUMENTS ORDERED TO BE PRODUCED BY THE COURT, AND TO SERVE A COPY OF YOUR RESPONSE TO SAID ORDER OF REFERENCE AND RULE TO SHOW CAUSE UPON THE ATTORNEY FOR PETITIONERS, C. STEVEN MOSKOS, AT HIS OFFICE LOCATED AT 4000 FABER PLACE DRIVE, SUITE 300, NORTH CHARLESTON, SOUTH CAROLINA 29405, WITHIN THIRTY (30) DAYS OF THE SERVICE HEREOF, EXCLUSIVE OF THE DAY OF SUCH SERVICE.

YOU ARE HEREBY GIVEN NOTICE FURTHER THAT IF YOU FAIL TO APPEAR AND RESPOND TO SAID ORDER OF REFERENCE AND RULE TO SHOW CAUSE AS REQUIRED BY THIS SUMMONS WITHIN THIRTY (30) DAYS AFTER THE SERVICE HEREOF, JUDGMENT BY DEFAULT WILL BE RENDERED AGAINST YOU FOR THE RELIEF DEMAND.

YOU ARE FURTHER NOTIFIED that a hearing supplemental proceedings in this matter, pursuant to the Rule to Show Cause, Order and Order of Reference, will be held on Monday, December 7, 2020 at 11:30 a.m. before the Honorable Mikael R.

Scarborough, Master-in-Equity/ Special Referee for Charleston County, at the Charleston County Courthouse, 100 Broad St., Suite 266, Charleston, SC 29401. Be present, if so minded.

C. STEVEN MOSKOS, P.A.
 ATTORNEY FOR PETITIONERS
 BY: SC. STEVEN MOSKOS
 SC BAR# 7938
 4000 FABER PLACE DR.,
 STE. 300
 NORTH CHARLESTON, SC 29405
 TELEPHONE: (843) 763-5297
 STEVE@MOSKOSLAWFIRM.COM
 CHARLESTON SOUTH CAROLINA
 SEPTEMBER 14, 2020

STATE OF SOUTH CAROLINA COUNTY OF CHARLESTON IN THE FAMILY COURT NINTH JUDICIAL CIRCUIT CASE NO: 2019-DR-10-2510

ROBERT LEONARD and SHANNON LEONARD,
 Plaintiffs,
 vs.
 SARAH FRAZIER, GERALD FRAZIER, and BABY GIRL L.A. minor under the age of seven (7) years,
 Defendant.

SUMMONS

TO THE DEFENDANTS SARAH FRAZIER, GERALD FRAZIER, AND BABY GIRL L.A. MINOR UNDER THE AGE OF SEVEN (7) YEARS: YOU ARE HEREBY SUMMONED to answer the Complaint heretofore served upon you, and to serve a copy of your Answer to said Complaint upon the subscriber Shannon Jones, Esquire, of the Shannon Jones Law Firm, LLC at her office at 3 State Street, Charleston, SC 29401, within thirty (30) days of the service heretofore, exclusive of the day of such service.

YOU ARE HEREBY GIVEN NOTICE FURTHER that, if you do not appear or answer the Complaint as required by this Summons within thirty (30) days after the service heretofore, judgment by default may be rendered per the relief requested in the Complaint.

SHANNON JONES LAW FIRM, LLC
 Shannon Jones, Esquire
 3 State Street
 Charleston, SC 29401
 Telephone: (843) 720-3100
 Facsimile: (843) 720-5999
 ATTORNEY FOR PLAINTIFFS
 September 23, 2020
 Charleston, South Carolina

STATE OF SOUTH CAROLINA COUNTY OF DORCHESTER IN THE COURT OF COMMON PLEAS FOR THE FIRST JUDICIAL CIRCUIT CASE NO: 2020-CP-18-00625

CRYSTAL L. HARPER, CAVEN D. HARPER, and OJTRAN JORNSON
 Plaintiffs,
 vs.
 ALFRED GOVAN,
 Defendant.

SUMMONS

TO: THE DEFENDANT ABOVE NAMED:

YOU ARE HEREBY SUMMONED and required to answer the Complaint in this action of which a copy is herewith served upon you, and to serve a copy of your Answer to the said Complaint upon the subscriber at 1317-M N. Main St. #940, Summerville, SC 29483 within thirty (30) days after the service heretofore, exclusive of the day of such service. If you fail to answer the Complaint within the time aforesaid, the Plaintiff in this action shall apply to the Court for the relief demanded in the Complaint and a judgment will be rendered against you.

ROSSINGTON LAW OFFICES, LLC
 of Julio A. Rossington
 Julio A. Rossington, SC Bar #73905
 1317-M N Main St. #140
 Summerville, SC 29483

Office: (843) 261-1114
 Facsimile: 1-888-977-1140
 julio.rossington@rossingtonlaw.com
 Attorney for the Plaintiff!

APRIL 2, 2020
 Summerville, South Carolina

STATE OF SOUTH CAROLINA COUNTY OF CHARLESTON IN THE FAMILY COURT FOR THE NINTH JUDICIAL CIRCUIT CASE NUMBER: 2020-DR-10-376

ELENA PEREZ MARTINEZ,
 Petitioner,
 vs.
 TEODILO RODRIGUEZ-FLORES,
 Respondent.

SUMMONS

YOU ARE HEREBY SUMMONED and required to answer the Petition heretofore served upon you, and to serve your Answer to said Petition upon the undersigned attorney for the Petitioner, at his offices located at 800 Wappoo Road, Charleston, South Carolina 29407, within thirty (30) days after the service heretofore, exclusive of the day of such service and, if you fail to answer the Petition within the time aforesaid, the Petitioner will apply to the Court for the relief demanded in the Petition.

YOU ARE HEREBY GIVEN NOTICE FURTHER that if you fail to appear and defend and fail to answer the Petition as required by this Summons within thirty (30) days after the service heretofore, exclusive of the day of service, judgment by Default will be rendered against you for the relief demanded in the Petition.

G. EDWARD HAYMONS, III
 HAYMONS LAW FIRM, P.A.
 800 Wappoo Road
 Charleston, SC 29407
 (843) 225-7565
 (843) 225-7585 fax
 ATTORNEY FOR PETITIONER
 Charleston, South Carolina
 September 23, 2020

STATE OF SOUTH CAROLINA COUNTY OF CHARLESTON IN THE COURT OF COMMON PLEAS Case No.: 2020-CP-1003491

SUMMONS AND NOTICE

Dorothy K. Rittenberg,
 Plaintiff
 vs.
 Cameron Michael Mones,
 Defendant.

TO THE DEFENDANT ABOVE NAMED: You are hereby summoned and required to answer the Complaint in this action, a copy of which is served upon you, and to serve a copy of your Answer to the Complaint upon the subscriber at 314 West 5th North Street, Summerville, SC 29483 within thirty days after service heretofore, exclusive of the day of such service. If you fail to answer the Complaint within that time, Plaintiff will apply to the Court for the relief demanded in the Complaint, and a judgment by default will be rendered against you for the relief demanded in the Complaint. In the event of a default, Plaintiff will apply for judgment to be made at chambers ten days after the last day for answering, as provided by law.

H. Abby Fulmer, II
 Attorney for Plaintiff
 314 West 5th North Street
 Summerville, SC 29484
 (843) 821-0909
 Filed August 12, 2020

Fall Fun Awaits...
 Experience the Beauty & Adventure

cypressgardens.info
 Call or Visit Us on Facebook for Details
 3030 Cypress Gardens Rd. | Moncks Corner 843-553-0515

FRESH AIR AND GOOD MUSIC?

CITY PAPER TICKETS
 CITYPAPERTICKETS.COM

HOSTING AN OUTDOOR EVENT?

For info on using City Paper Tickets for your next event contact Melissa @ charlestoncitypaper.com

BURRIS liquor
 Family Owned Since 1968

FOR LIFE'S EVERY Celebration

WINE • APERTIFS/CORDIALS • BOURBON • BRANDY • COGNAC • GIN MIXERS • RUM • SCOTCH • TEQUILA • VODKA • WHISKEY AND MORE!
 418 Meeting St. (Corrier of Meeting & Reid) • 843-723-0077 • burrisliquors.com

HAVE YOU BEEN SERVED?

Search the State Database for legal notices.

HTTP://SCPUBLICNOTICES.COM



AM before the Honorable Mitchell Scarborough, Master-in-Equity for Charleston County for the purpose of taking testimony, findings of facts and conclusions of law and to enter final judgment therein without further order of the court. This hearing will be held using remote communication technology to avoid the need for a physical appearance by any party, witness, or counsel, as provided for in South Carolina Supreme Court Administrative Order 2020-04-30-02 (RE: Statewide Evictions and Foreclosures) and South Carolina Supreme Court Administrative Order 2020-04-22-01 (RE: Operation of the Trial Courts During the Coronavirus Emergency). The hearing will be conducted by the Master-in-Equity Judge via the Court's Cisco Webex video conference system, which has both audio and video capabilities. To join the video conference, please go to <https://charlestoncounty.org/webex/join> in the upper right-hand corner of the screen. The MEETING NUMBER is 725 06 73 followed by the ACCESS CODE: Hearings02B. If you need assistance joining (using either the audio or video method), please call our office for additional instructions on how to use Cisco Webex for the hearing. If you wish to attend by telephone only you may dial (803) 418-9388 and enter ACCESS CODE: 173 562 8672. If you do not have either audio or video capabilities, you may physically attend the hearing at the Charleston County Courthouse, 100 Broad Street, Suite 266, Charleston SC 29401, subject to all county-specific and court-specific COVID-19 requirements and restrictions. If you choose to physically attend the hearing, you must, at all times, wear a mask or other facial covering, as mandated in South Carolina Supreme Court Administrative Order 2020-04-30-02 (RE: Statewide Evictions and Foreclosures). Additionally and most importantly, if you plan to physically attend the hearing, please contact our office at (803) 406-5700 or the Master-in-Equity's office (843-958-5053) within 24 hours of the scheduled hearing date and time referenced above, so Court personnel may be alerted as to your attendance. **ONLY NAMED DEFENDANTS AND/OR THEIR ATTORNEYS WILL BE ALLOWED ACCESS TO THE COURT HOUSE.** If you plan to join or attend this hearing, we would respectfully appreciate your sending an email to wictoria@paynelawoffice.com or leaving a message for the undersigned at (843) 606-5700. (This is for purpose of notifying you in the event that the hearing is canceled.)

v/Victoria N. Smith
Victoria N. Smith, Esq. (011864)
280 Seven Farms Drive
Suite A
Daniel Island, SC 29492
(843) 606-5700
September 18, 2020
Daniel Island, South Carolina

STATE OF SOUTH CAROLINA
COUNTY OF CHARLESTON IN
THE COURT OF COMMON PLEAS
CASE NO.: 2020-CP-10-00266
Wilma Keith,
Plaintiff,
vs.
Susie Brown (deceased); Herman
Brown (deceased); William
Spain (deceased); The Estate
of Lindsey A. Johnson; Aida A.
Vivrette; Keith D. Johnson; Leslie
M. Johnson; Cynthia Bailey;
Charles Brown, Jr.; Rogge S.
Jackson; Jacquelin Brown, John
Doe and Jane Doe, a fictitious
name used herein to designate
the estates and unknown heirs-
at-law, distributees, devisees,
issue, personal representatives,
assigns, administrators, creditors,
successors, children and/or
spouse of Susie Brown, Herman
Brown, William Spain, Leslie
Johnson, or Lindsey A. Johnson,
and Mary Roe, a fictitious name
designating all other persons
and legal entities unknown who
may have or claim any right, title,
estate, and/or interest in or to

upon the real estate described herein, including such as may be, in whole or in part, by any other instrument, including the Servicemembers Civil Relief Act, Defendants.

NOTICE OF FINAL HEARING
(By Video/Telephone Conference)

TO ALL DEFENDANTS
A final hearing has been set in the above-captioned matter for October 15, 2020 at 3:00 PM before the Honorable Mitchell Scarborough, Master-in-Equity for Charleston County, for the purpose of taking testimony, findings of facts and conclusions of law and to enter final judgment therein without further order of the court. This hearing will be held using remote communication technology to avoid the need for a physical appearance by any party, witness, or counsel, as provided for in South Carolina Supreme Court Administrative Order 2020-04-30-02 (RE: Statewide Evictions and Foreclosures) and South Carolina Supreme Court Administrative Order 2020-04-22-01 (RE: Operation of the Trial Courts During the Coronavirus Emergency). The hearing will be conducted by the Master-in-Equity Judge via the Court's Cisco Webex video conference system, which has both audio and video capabilities. To join the video conference, please go to <https://charlestoncounty.org/webex/join> in the upper right-hand corner of the screen. The MEETING NUMBER is 725 06 73 followed by the ACCESS CODE: Hearings02B. If you need assistance joining (using either the audio or video method), please call our office for additional instructions on how to use Cisco Webex for the hearing. If you wish to attend by telephone only you may dial (803) 418-9388 and enter ACCESS CODE: 173 562 8672. If you do not have either audio or video capabilities, you may physically attend the hearing at the Charleston County Courthouse, 100 Broad Street, Suite 266, Charleston SC 29401, subject to all county-specific and court-specific COVID-19 requirements and restrictions. If you choose to physically attend the hearing, you must, at all times, wear a mask or other facial covering, as mandated in South Carolina Supreme Court Administrative Order 2020-04-30-02 (RE: Statewide Evictions and Foreclosures). Additionally and most importantly, if you plan to physically attend the hearing, please contact our office at (803) 406-5700 or the Master-in-Equity's office (843-958-5053) within 24 hours of the scheduled hearing date and time referenced above, so Court personnel may be alerted as to your attendance. **ONLY NAMED DEFENDANTS AND/OR THEIR ATTORNEYS WILL BE ALLOWED ACCESS TO THE COURT HOUSE.** If you plan to join or attend this hearing, we would respectfully appreciate your sending an email to wictoria@paynelawoffice.com or leaving a message for the undersigned at (843) 606-5700. (This is for purpose of notifying you in the event that the hearing is canceled.)

v/Victoria N. Smith
Victoria N. Smith, Esq. (011864)
280 Seven Farms Drive, Suite A
Daniel Island, SC 29492
(843) 606-5700
September 15, 2020
Daniel Island, South Carolina

Master's Sale (Amended)
Case No. 2019-CP-10-03111

STATE OF SOUTH CAROLINA
COUNTY OF CHARLESTON
IN THE COURT OF COMMON PLEAS

TBG Funding LLC,
vs.
Seven and Rose, LLC, MCRFO, LLC
and Wells Fargo Vendor Financial
Services LLC.

Upon Authority of a Decree dated the 21st day of January, 2020, I will offer for sale to the highest bidder for cash, at public auction, the premises fully described be-

low, at the County Council Chambers, 4045 Bridge View Drive, North Charleston, South Carolina on the 6th day of August, 2020, at 11:00 a.m. or shortly thereafter. Since the two lots have been reconfigured into one, both units will be sold together as one. Unit 202, All that certain apartment lying and being in the City of Charleston, Charleston County, South Carolina, and being known as 500 S. 20th Street, East Bay Historical Property Regime, and being more particularly shown and described by reference to the Master Deed of 198 East Bay Historical Property Regime filed by Kathleen Hyde establishing said Historical Property Regime, said Master Deed being dated the 3rd day of December, 1981, and being recorded in the REC Office for Charleston County in Deed Book F127, Page 65. Together with an undivided percentage interest in the common elements and facilities of the said apartment, this being a portion of the same property conveyed to Seven and Rose, L.L.C., a South Carolina limited liability company, by Deed of Cumberland Bay Properties, a South Carolina partnership, dated March 4, 2016 and being recorded in the REC Office of the Register of Deeds for Charleston County, South Carolina, TMS No. 458-05-04-019, Unit 201. All that certain apartment lying and being in the City of Charleston, Charleston County, South Carolina, and being known as Suite 201 of the 198 East Bay Historical Property Regime and being more particularly shown and described by reference to the Master Deed of 198 East Bay Historical Property Regime filed by Kathleen Hyde establishing said Historical Property Regime, said Master Deed being dated the 3rd day of December, 1981, and being recorded in the REC Office for Charleston County in Deed Book F127, Page 65. Together with an undivided percentage interest in the common elements and facilities of the properties described in the aforesaid Master Deed and attributable to the said apartment, this being a portion of the same property conveyed to MCRFO, a Nevada limited liability company, by Deed of A.L.D. Company, dated October 14, 2015 and recorded October 15, 2015 in Book 510 at Page 907 in the Office of the Register of Deeds for Charleston County, South Carolina, TMS No. 458-05-04-020. Current Property Address: 198 East Bay Street, Units 200 and 201, Charleston, SC 29401. No personal or deficiency judgment being demanded, the highest bidder, other than the Plaintiff, will be required to deposit with the Master, at the conclusion of the bidding, cash or certified check in the amount of five (5%) per cent of the bid; the said deposit to comply with the bid within thirty days from the date of sale; the Master will resell the property at the risk and expense of the defaulting bidder upon the same terms as above set out. The Sheriff of Charleston County may be authorized to the purchaser into possession of the premises if requested by the purchaser.

PLAINTIFF'S ATTORNEY
J. Kenneth Spang, Esquire
Telephone: (803) 939-1400
FOR INSERTION September 16,
23 & 30, 2020
Mitchell R. Scarborough
Master in Equity

STATE OF SOUTH CAROLINA
COUNTY OF CHARLESTON IN
THE COURT OF COMMON PLEAS
DOCKET NO. 2020-CP-10-03392

South Carolina Department of Social Services,
vs.
Neszeja Robinson et al.

NOTICE
TO ALL INTERESTED PARTIES:
You are hereby summoned and required to answer the Complaint in this action filed with the Clerk of Court for Charleston County on April 20, 2020. Upon proof of interest, a copy of the Complaint will be delivered to you upon request from the Clerk of Court in Charleston, and you must serve a copy of your

STATE OF SOUTH CAROLINA
COUNTY OF CHARLESTON IN
THE COURT OF COMMON PLEAS
DOCKET NO. 2020-CP-10-03392

South Carolina Department of Social Services,
vs.
Neszeja Robinson et al.

NOTICE
TO ALL INTERESTED PARTIES:
You are hereby summoned and required to answer the Complaint in this action filed with the Clerk of Court for Charleston County on April 20, 2020. Upon proof of interest, a copy of the Complaint will be delivered to you upon request from the Clerk of Court in Charleston, and you must serve a copy of your

NAMED:
YOU ARE HEREBY SUMMONED and required to answer the Complaint in this action of which a copy is herewith served upon you, and to serve a copy of your Answer on the undersigned at his offices, 1704 Main Street, Post Office Box 58, Columbia, South Carolina 29202, within thirty (30) days after the service hereof. Your answer must be in writing and signed by you or by your attorney and must state your address or the address of your attorney, if signed by your attorney.

McDONALD, McKEENZIE, RUBIN, MILLER AND LYBRAND, L.L.P.
Post Office Box 58
Columbia, South Carolina 29202
(803) 252-0500
John F. McKeenie
Attorney for the Plaintiff
August 5, 2020

NOTICE
TO THE DEFENDANT MARIO ANDRE BENNETT:
Notice is hereby given that the Complaint in the foregoing action, together with the Summons, of which the foregoing is a copy, was filed in the Office of the Clerk of Court for Charleston County on the 5th day of August, 2020.

McDONALD, McKEENZIE, RUBIN, MILLER AND LYBRAND, L.L.P.
Post Office Box 58
Columbia, South Carolina 29202
(803) 252-0500
John F. McKeenie
Attorney for the Plaintiff
September 23, 2020

STATE OF SOUTH CAROLINA
COUNTY OF CHARLESTON IN
THE FAMILY COURT FOR
THE NINTH JUDICIAL CIRCUIT
DOCKET NO. 2020-DR-10-1444

SOUTH CAROLINA DEPARTMENT OF SOCIAL SERVICES
VERSUS
Ebony I Glover

NOTICE TO Ebony I Glover:
You are hereby summoned and required to answer the Complaint in this action filed with the Clerk of Court for Charleston County on June 12, 2020 and the Amended Complaint in this action filed with the Clerk of Court for Charleston County on July 8, 2020. Upon proof of interest, a copy of the Complaint will be delivered to you upon request from the Clerk of Court in Charleston, and you must serve a copy of your Answer to the Complaint on the Plaintiff, the Charleston County Department of Social Services, at the office of their Attorney, Kenneth Murphy, II, at the Legal Department of the Charleston County Department of Social Services, 3366 Rivers Ave., II, Charleston, South Carolina 29405-5714, within thirty days of this publication. If you fail to answer within the time set forth above, the Plaintiff will proceed to seek relief from the Court.

STATE OF SOUTH CAROLINA
COUNTY OF CHARLESTON IN
THE FAMILY COURT FOR
THE NINTH JUDICIAL CIRCUIT
DOCKET NO. 2020-DR-10-1053

SOUTH CAROLINA DEPARTMENT OF SOCIAL SERVICES
VERSUS
Neszeja Robinson et al.

NOTICE
TO ALL INTERESTED PARTIES:
You are hereby summoned and required to answer the Complaint in this action filed with the Clerk of Court for Charleston County on April 20, 2020. Upon proof of interest, a copy of the Complaint will be delivered to you upon request from the Clerk of Court in Charleston, and you must serve a copy of your

Answer to the Complaint on the Plaintiff, the Charleston County Department of Social Services, at the office of their Attorney, Sally R. Young of the Charleston County Department of Social Services, 3366 Rivers Ave., II, Charleston, South Carolina 29405-5714, within thirty days of this publication. If you fail to answer within the time set forth above, the Plaintiff will proceed to seek relief from the Court.

STATE OF SOUTH CAROLINA
COUNTY OF CHARLESTON
IN THE MAGISTRATE'S COURT
CIVIL CASE NUMBER
2020CV011501116

Darryl D Henricks
321 Cabell St
Charleston, SC 29407
(509) 947.7354
PLAINTIFF(S)

Magnus Stier
The Edgewater Kitchens
1954 DuSoy Rd
Charleston, SC 29407
DEFENDANT(S)

SUMMONS
TO THE DEFENDANT(S) NAMED ABOVE:
YOU ARE SUMMONED and required to answer the allegations of the attached Complaint and present any appropriate counterclaims/crossclaims to the attached Complaint within THIRTY days from the first day after the receipt of this summons. Your Answer must be received by the:

Small Claims
North 4045 Bridge View Drive
P. O. Box 70125
North Charleston, SC 29405
Phone: (843) 202-6650
Fax: (843) 202-6652

If you fail to answer within the prescribed time, a judgment by default may be rendered against you for the amount or other relief requested in the attached Complaint, plus interest and costs. If you desire a jury trial, you must request one in writing prior to the date set for trial. If no jury trial is timely requested, the matter will be heard and decided by the Judge.

August 5, 2020
MWRJ SCCN700
(Amended 12/2015)

STATE OF SOUTH CAROLINA
COUNTY OF CHARLESTON IN
THE COURT OF COMMON PLEAS
FOR THE NINTH JUDICIAL CIRCUIT
CASE NO.: 2019-CP-10-03689

JESSICA NEAGS AND HALL & MEANS, LLC,
PETITIONERS,
VS.
DONALD B. MCCUTCHEON,
RESPONDENT

SUMMONS
TO THE DEFENDANT ABOVE NAMED:
YOU ARE HEREBY SUMMONED AND REQUIRED TO RESPOND TO THE ORDER OF REFERENCE AND RULE TO SHOW CAUSE FILED WITH THE CHARLESTON COUNTY CLERK OF COURT ON FEBRUARY 25, 2020 AND TO PROVIDE THE DOCUMENTS ORDERED TO BE PRODUCED BY THE COURT, AND TO SERVE A COPY OF YOUR RESPONSE TO SAID ORDER OF REFERENCE AND RULE TO SHOW CAUSE UPON THE ATTORNEY FOR PETITIONERS, C. STEVEN MOSKOS, AT HIS OFFICE LOCATED AT 4000 FABER PLACE DRIVE, SUITE 300, NORTH CHARLESTON, SOUTH CAROLINA 29405, WITHIN THIRTY (30) DAYS OF THE SERVICE HEREOF, EXCLUSIVE OF THE DAY OF SUCH SERVICE.

STATE OF SOUTH CAROLINA
COUNTY OF CHARLESTON IN
THE COURT OF COMMON PLEAS
2020-CP-10-01612

WILLIAM J. ORBACH AND
CAROLIN E. ORBACH
Plaintiffs
vs.
Cameron Michael Mones,
Defendant.

TO THE DEFENDANT ABOVE NAMED:
You are hereby summoned and required to answer the Complaint in this action, a copy of which is served upon you, and to serve a copy of your Answer to the Complaint upon the undersigned at 314 West 5th North Street, Summerville, SC 29483 within thirty days after service hereof, exclusive of the day of such service. If you fail to answer the Complaint within that time, Plaintiff will apply to the Court for the relief demanded in the Complaint, and a judgment by default will be rendered against you for the relief demanded in the Complaint. In the event of a default, Plaintiff will apply for judgment to be made at chambers ten days after the last day for answering, as

RENDERED AGAINST YOU FOR THE RELIEF DEMANDED.
YOU ARE FURTHER NOTIFIED that a hearing supplemental proceedings in this matter, pursuant to the Rule to Show Cause, Order and Order of Reference, will be held on Wednesday, December 7, 2020 at 11:30 a.m. before the Honorable Mitchell R. Scarborough, Master-in-Equity/Special Referee for Charleston County, at the Charleston County Courthouse, 100 Broad St., Suite 266, Charleston, SC 29401. Be present, if so minded.

C. STEVEN MOSKOS, P.A.
ATTORNEY FOR PETITIONERS
BY: C. STEVEN MOSKOS
SC BAR# 7938
4000 FABER PLACE DR.,
STE. 300
NORTH CHARLESTON, SC 29405
TELEPHONE: (843) 763-5257
STEVENMOSKOSLAWFIRM.COM
CHARLESTON, SOUTH CAROLINA
SEPTEMBER 14, 2020

STATE OF SOUTH CAROLINA
COUNTY OF CHARLESTON
IN THE FAMILY COURT
NINTH JUDICIAL CIRCUIT
CASE NO.: 2019-DR-10-2510

ROBERT LEONARD and
SHANNON LEONARD,
Plaintiffs,
vs.
SARAH FRAZIER, GERALD FRAZIER,
FRABY GIBL, J.A. minor
under the age of seven (7) years,
Defendant.

SUMMONS
TO THE DEFENDANTS SARAH FRAZIER, GERALD FRAZIER, AND FRABY GIBL, J.A. MINOR UNDER THE AGE OF SEVEN (7) YEARS:
YOU ARE HEREBY SUMMONED to answer the Complaint herein, a copy of which is herewith served upon you, and to serve a copy of your Answer to said Complaint upon the undersigned attorney for the Petitioner, at his offices located at 800 Wappoon Road, Charleston, South Carolina 29407, within thirty (30) days after the service hereof, exclusive of the day of such service. If you fail to answer the Petition as required by this Summons within thirty (30) days after the service hereof, judgment by default may be rendered against you for the relief requested in the Petition.

SHANNON JONES LAW FIRM, LLC
Shannon Jones, Esq.
3 State Street
Charleston, SC 29401
Telephone: (843) 720-3100
Facsimile: (843) 720-5999
ATTORNEY FOR PLAINTIFFS
September 23, 2020
Charleston, South Carolina

STATE OF SOUTH CAROLINA
COUNTY OF CHARLESTON IN
THE COURT OF COMMON PLEAS
2020-CP-10-01612

WILLIAM J. ORBACH AND
CAROLIN E. ORBACH
Plaintiffs
vs.
ARNETT CONSTRUCTION, LLC;
A. RAMOS BRICK & BLOCK, LLC;
CRAWFORD CONTRACTING
AND CONSULTING, LLC; DRY
ROOFING & EXTERIORS, INC.;
BOBCKET PLUMBING, WASSON
ELECTRIC, WASSON HEATING
& AIR SERVICES, CLEAN USA,
INC. DRINK LOWCOUNTRY
BASEMENTS SYSTEMS, RENTON
SUBSERVICES, LLC; RUIII, MARTINEZ
MASONRY, LLC; ROBERTS CLEAN
UP, INC.; JOSE MIRANDA DA
CURVA; DANIEL J. MURPHY; US
DRBA PERFECTLY PAINTED; USA
CONSTRUCTION, LLC; CARLOS
MANROQUIN, INDIVIDUALLY;
JAMES BAYLES, INDIVIDUALLY;
BARANOV FLOORING, LLC
Defendants.

AMENDED SUMMONS
(Jury Trial Demanded)

YOU ARE HEREBY SUMMONED and required to answer the Amended Complaint in this ac-

tion, a copy of which is herewith served upon you, and to serve a copy of your Answer upon the undersigned, at 234 Seven Farms Drive, Suite 111-A, South Carolina 29484, within thirty (30) days after the service hereof, exclusive of the day of such service, and if you fail to answer the Amended Complaint within the time aforesaid, judgment by default will be rendered against you for the relief demanded in the Amended Complaint.

BLINDLY LAW FIRM, LLC
Amanda M. Blundy, Esq.
Erin H. Hadd, Esq.
234 Seven Farms Drive
Suite 111-A
Charleston, SC 29492
843.867.6050
ablundy@blindlylawfirm.com
ahadd@blindlylawfirm.com
Attorneys for Plaintiffs

STATE OF SOUTH CAROLINA
COUNTY OF CHARLESTON
IN THE NINTH JUDICIAL CIRCUIT
CASE NUMBER: 2020-DR-10-376

ELENA PEREZ MARTINEZ,
Petitioner,
vs.
TEODORO RODRIGUEZ-FLORES,
Respondent.

SUMMONS
YOU ARE HEREBY SUMMONED and required to answer the Petition herein, a copy of which is herewith served upon you, and to serve your Answer to said Petition upon the undersigned attorney for the Petitioner, at his offices located at 800 Wappoon Road, Charleston, South Carolina 29407, within thirty (30) days after the service hereof, exclusive of the day of such service. If you fail to answer the Petition as required by this Summons within thirty (30) days after the service hereof, judgment by default may be rendered against you for the relief requested in the Petition.

G. EDWARD HAWKINS, III
HAWKINS LAW FIRM, P.A.
800 Wappoon Road
Charleston, SC 29407
Phone: (843) 720-5999
(843) 225-7885
fax: (843) 720-5999
ATTORNEY FOR PETITIONER
Charleston, South Carolina
September 23, 2020

STATE OF SOUTH CAROLINA
COUNTY OF CHARLESTON IN
THE COURT OF COMMON PLEAS
Case No.: 2020-CP-1003491

SUMMONS AND NOTICE
Dorothy K. Ritzenberg,
Plaintiff
vs.
Cameron Michael Mones,
Defendant.

TO THE DEFENDANT ABOVE NAMED:
You are hereby summoned and required to answer the Complaint in this action, a copy of which is served upon you, and to serve a copy of your Answer to the Complaint upon the undersigned at 314 West 5th North Street, Summerville, SC 29483 within thirty days after service hereof, exclusive of the day of such service. If you fail to answer the Complaint within that time, Plaintiff will apply to the Court for the relief demanded in the Complaint, and a judgment by default will be rendered against you for the relief demanded in the Complaint. In the event of a default, Plaintiff will apply for judgment to be made at chambers ten days after the last day for answering, as

STATE OF SOUTH CAROLINA
COUNTY OF CHARLESTON IN
THE COURT OF COMMON PLEAS
CASE NO.: 2020-CP-10-00266

Wilma Keith,
Plaintiff,
vs.
Susie Brown (deceased); Herman
Brown (deceased); William
Spain (deceased); The Estate
of Lindsey A. Johnson; Aida A.
Vivrette; Keith D. Johnson; Leslie
M. Johnson; Cynthia Bailey;
Charles Brown, Jr.; Rogge S.
Jackson; Jacquelin Brown, John
Doe and Jane Doe, a fictitious
name used herein to designate
the estates and unknown heirs-
at-law, distributees, devisees,
issue, personal representatives,
assigns, administrators, creditors,
successors, children and/or
spouse of Susie Brown, Herman
Brown, William Spain, Leslie
Johnson, or Lindsey A. Johnson,
and Mary Roe, a fictitious name
designating all other persons
and legal entities unknown who
may have or claim any right, title,
estate, and/or interest in or to

provided by law.
H. Asby Fulmer, II
Attorney for Plaintiff
314 West 5th North Street
Summerville, SC 29484
(843) 821-0909
Filed August 12, 2020

NOTICE OF PUBLIC HEARING
Notice is hereby given that Charleston County Council will hold a public hearing on Tuesday, October 20, 2020, at 6:30 p.m., in the Beverly I. Green Council Chambers, Linn Hamilton, III Public Services Building, 4045 Bridge View Drive, North Charleston, SC for the purpose of receiving public comment on amending portions of Section 2-137 in the Charleston County Code of Ordinances to amend Short-Term Rental Zoning Permit Application fees.
Public comments, written and oral, are invited. Submission of written public comments is encouraged and those wishing to provide written public comments for the public hearing should email comments@charlestoncounty.org by 6:30 p.m. on Tuesday, October 6, 2020.
Kristen L. Salisbury
Clerk of Council



NOTICE OF PUBLIC HEARING
Notice is hereby given that Charleston County Council will hold a public hearing on Thursday, October 15, 2020, at 5:00 o'clock p.m., in the Beverly I. Green Council Chambers, Linn Hamilton, III Public Services Building, 4045 Bridge View Drive, North Charleston, SC for the purpose of receiving public comment on amending portions of Section 2-137 in the Charleston County Code of Ordinances to amend Short-Term Rental Zoning Permit Application fees.
Public comments, written and oral, are invited. Submission of written public comments is encouraged and those wishing to provide written public comments for the public hearing should email comments@charlestoncounty.org by 5:00 p.m. on Thursday, October 15, 2020.
Kristen L. Salisbury
Clerk of Council

NOTICE OF PUBLIC HEARING
Notice is hereby given that Charleston County Council will hold a public hearing on Thursday, October 15, 2020, at 5:00 o'clock p.m., in the Beverly I. Green Council Chambers, Linn Hamilton, III Public Services Building, 4045 Bridge View Drive, North Charleston, SC for the purpose of receiving public comment on amending portions of Section 2-137 in the Charleston County Code of Ordinances to amend Short-Term Rental Zoning Permit Application fees.
Public comments, written and oral, are invited. Submission of written public comments is encouraged and those wishing to provide written public comments for the public hearing should email comments@charlestoncounty.org by 5:00 p.m. on Thursday, October 15, 2020.
Kristen L. Salisbury
Clerk of Council



WELCOME REAL PROPERTY RECORD SEARCH REAL PROPERTY BILL SEARCH PERSONAL PROPERTY SEARCH

MOTOR VEHICLE SEARCH CHECKOUT CONTACT US

\$0.00
CHECKOUT

RETURN PRINT

PROPERTY INFO

Account Information

Last Update: 8/18/2020 2:07:23 AM

Parcel Number	Alternate Number	Property Type
3511300011		Real
Owner Information		
Current Owner: SHIER MAGNUS EUGENE III 1956 DULSEY RD CHARLESTON, SC 29407-5722		
Location Information		
Physical Address: 1954 DULSEY RD CHARLESTON SC 29407		
TAG# 6-2 ST ANDREWS PSD		
Legal Description		
Subdivision Name -ORLEANS ESTATES Description -PT 11B		

Tax Bills

PERIOD	DUE DATE	TAX	PENALTY	INTEREST	FEES	TOTAL DUE	STATUS
2019	1/15/2020	\$1,966.08	\$0.00	\$0.00	\$0.00	\$1,966.08	Paid
2019	1/15/2019	\$1,900.03	\$0.00	\$0.00	\$0.00	\$1,900.03	Paid
2017	1/16/2018	\$1,866.44	\$0.00	\$0.00	\$0.00	\$1,866.44	Paid
2016	1/17/2017	\$1,802.81	\$0.00	\$0.00	\$0.00	\$1,802.81	Paid

RETURN PRINT

PROPERTY INFO



Judge James Turner
Magistrate

NORTH AREA SMALL CLAIMS COURT

843.202-6650
Fax: 843.202-6652
Lonnie Hamilton, III Public
Services
Building
4045 Bridge View Drive
Post Office Box 70235
North Charleston, SC 29415-0235

November 5, 2020

Danny D. Henriksen
322 Cabell St.
Charleston, SC 29407

Magnus Shier dba
Edgewater Kitchens
1954 Dulsey Rd.
Charleston, SC 29407

**RE: Danny D. Henriksen vs Magnus Shier DBA Edgewater Kitchens
Case No.: 2020CV1011501116**

Notice to All Parties:

Please be advised that a Default Hearing has **been scheduled** for:

Friday, November 20, 2020 AT 10:15 AM

**Please check in at the Small Claims counter prior to entering the
courtroom.**

Sincerely,

Linda West
Summary Court Specialist



NORTH AREA SMALL CLAIMS COURT

4045 Bridge View Drive
North Charleston, SC 29405-7476

Return Service Requested

Magnus Shier dba
Edgewater Kitchens
1954 Dulsey Rd.
Charleston, SC 29407



NORTH AREA SMALL CLAIMS COURT

4045 Bridge View Drive
North Charleston, SC 29405-7476

Return Service Requested

Danny D. Henriksen
322 Cabell St.
Charleston, SC 29407

ORIGINAL

STATE OF SOUTH CAROLINA)

2020CV1011501116
CIVIL CASE NUMBER

COUNTY OF CHARLESTON)

IN THE MAGISTRATE'S COURT

TRANSCRIPT OF JUDGMENT
FIND FOR PLAINTIFF

Names of Parties Against Whom Judgment is Granted	Attorneys
Magnus Shier Dba Edgewater Kitchens 1954 Dulsey Rd. Charleston, SC 29407	

Names of Parties To Whom Judgment is Granted	Attorneys
Danny D Henriksen 322 Cabell St. Charleston, SC 29407	

DAMAGES AND COSTS

Amount of Judgment:	\$6,662.00
Costs:	
Court Costs / Filing Fees	\$296.00
Interest	\$0.00
Attorney Fees	\$0.00
Total Amount of Judgment:	\$6,958.00
Date of Judgment:	11/20/2020

I, James A Turner, Magistrate in and for the County of Charleston, do hereby certify that the foregoing is a correct transcript of the Judgment issued by this Court.

James A Turner
Charleston County Magistrate

November 20, 2020



NORTH AREA SMALL CLAIMS COURT

4045 Bridge View Drive
North Charleston, SC 29405-7476

Return Service Requested

Magnus Shier dba
Edgewater Kitchens
1954 Dulsey Rd.
Charleston, SC 29407



NORTH AREA SMALL CLAIMS COURT

4045 Bridge View Drive
North Charleston, SC 29405-7476

Return Service Requested

Danny D. Henriksen
322 Cabell St.
Charleston, SC 29407

Small Claims - North

Judge : James A Turner

4045 Bridge View Drive

North Charleston, SC 29405

Phone:(843) 202-6650 Fax:(843) 202-6652

Received From: Shier

Date : 11/30/2020

RECEIPT # 497480

Clerk: SUMLIW

Paying for: Shier,

Payment Type: Credit Card \$23.00

Reference #: 2020CV1011501116

Convenience Fee \$0.39

Comment:

SC.gov Portal Fee \$1.00

Non-Refundable

Total Paid 24.39

Total Received \$23.00

Change Due \$0.00

X Turner

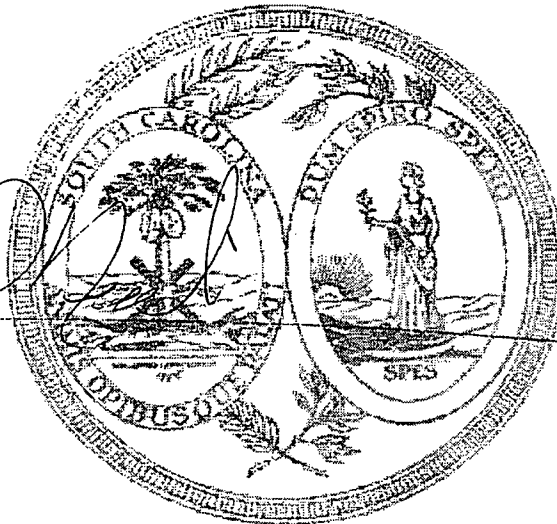

South Carolina ^{SC} USA

DRIVER'S LICENSE DL



Patricia R. O'Neil

1 DL# 102852074
2 ONEIL
3 PATRICIA R
4 1011 JOHNNIE DODDS BLVD
5 MOUNT PLEASANT, SC 29566138
6 DOB
7 Issued: 03/13/1998
8 Expires: 11/08/2018
9 Sex: F
10 Wgt: 200 lb 11 Hgt: 5-09
12 Class: 0 13 Eyes: BRO
14 Restrictions: None

5 DL# 1000100462288881108



843.202-6650
Fax: 843.202-6652
Lonnie Hamilton, III Public Services
Building
4045 Bridge View Drive
Post Office Box 70235
North Charleston, SC 29415-0235

Judge James Turner
Magistrate

NORTH AREA SMALL CLAIMS
COURT

January 4, 2021

Danny D. Henriksen
322 Cabell St.
Charleston, SC 29407

Magnus Shier DBA Edgewater Kitchens
1954 Dulsey Rd.
Charleston, SC 29407

RE: Danny D. Henriksen vs Magnus Shier DBA Edgewater Kitchens
CASE NO: 2020CV1011501116
COMMON PLEAS: 2020-CP-10-05405

Notice to all Parties:

Please find enclosed your copy of the **Magistrates Return** filed by the Honorable James Turner in regards to an Appeal filed by **Magnus Shier**, on the case referenced above on **December 9, 2020**, with the Charleston County Court of Common Pleas.

If I can be of any further assistance, feel free to contact this office.

Sincerely,

Linda West
Summary Court Specialist

Enclosure: Copy of Return

cc: File

STATE OF SOUTH CAROLINA

COUNTY OF Charleston

Magnus E Shreeff
Plaintiff(s)

IN THE COURT OF COMMON PLEAS

CIVIL ACTION COVERSHEET

2020 -CP- 10 - 5405

Danny D Henriksen
Defendant(s)

Submitted By: Magnus Shreeff
Address: 1954 Outsey Rd
Outs SC 29407

SC Bar #: _____
Telephone #: _____
Fax #: _____
Other: _____
E-mail: _____

NOTE: The coversheet and information contained herein neither replaces nor supplements the filing and service of pleadings or other papers as required by law. This form is required for the use of the Clerk of Court for the purpose of docketing cases that are NOT E-Filed. It must be filled out completely, signed, and dated. A copy of this coversheet must be served on the defendant(s) along with the Summons and Complaint. This form is NOT required to be filed in E-Filed Cases.

DOCKETING INFORMATION (Check all that apply)

**If Action is Judgment/Settlement do not complete*

- JURY TRIAL demanded in complaint. NON-JURY TRIAL demanded in complaint.
- This case is subject to ARBITRATION pursuant to the Court Annexed Alternative Dispute Resolution Rules.
- This case is subject to MEDIATION pursuant to the Court Annexed Alternative Dispute Resolution Rules.
- This case is exempt from ADR. (Proof of ADR/Exemption Attached)

NATURE OF ACTION (Check One Box Below)

- | | | | |
|---|---|--|---|
| <p>Contracts</p> <ul style="list-style-type: none"> <input type="checkbox"/> Constructions (100) <input type="checkbox"/> Debt Collection (110) <input type="checkbox"/> General (130) <input type="checkbox"/> Breach of Contract (140) <input type="checkbox"/> Fraud/Bad Faith (150) <input type="checkbox"/> Failure to Deliver/Warranty (160) <input type="checkbox"/> Employment Discrim (170) <input type="checkbox"/> Employment (180) <input type="checkbox"/> Other (199) _____ <p>Inmate Petitions</p> <ul style="list-style-type: none"> <input type="checkbox"/> PCR (500) <input type="checkbox"/> Mandamus (520) <input type="checkbox"/> Habeas Corpus (530) <input type="checkbox"/> Other (599) <p>Special/Complex /Other</p> <ul style="list-style-type: none"> <input type="checkbox"/> Environmental (600) <input type="checkbox"/> Automobile Arb. (610) <input type="checkbox"/> Medical (620) <input type="checkbox"/> Other (699) _____ <input type="checkbox"/> Sexual Predator (510) <input type="checkbox"/> Permanent Restraining Order (680) <input type="checkbox"/> Interpleader (690) | <p>Torts - Professional Malpractice</p> <ul style="list-style-type: none"> <input type="checkbox"/> Dental Malpractice (200) <input type="checkbox"/> Legal Malpractice (210) <input type="checkbox"/> Medical Malpractice (220) Previous Notice of Intent Case # <u>20 -NI-</u> <input type="checkbox"/> Notice/ File Med Mal (230) <input type="checkbox"/> Other (299) _____ <p>Administrative Law/Relief</p> <ul style="list-style-type: none"> <input type="checkbox"/> Reinstate Drv. License (800) <input type="checkbox"/> Judicial Review (810) <input type="checkbox"/> Relief (820) <input type="checkbox"/> Permanent Injunction (830) <input type="checkbox"/> Forfeiture-Petition (840) <input type="checkbox"/> Forfeiture-Consent Order (850) <input type="checkbox"/> Other (899) | <p>Torts - Personal Injury</p> <ul style="list-style-type: none"> <input type="checkbox"/> Conversion (310) <input type="checkbox"/> Motor Vehicle Accident (320) <input type="checkbox"/> Premises Liability (330) <input type="checkbox"/> Products Liability (340) <input type="checkbox"/> Personal Injury (350) <input type="checkbox"/> Wrongful Death (360) <input type="checkbox"/> Assault/Battery (370) <input type="checkbox"/> Slander/Libel (380) <input type="checkbox"/> Other (399) _____ <p>Judgments/Settlements</p> <ul style="list-style-type: none"> <input type="checkbox"/> Death Settlement (700) <input type="checkbox"/> Foreign Judgment (710) <input type="checkbox"/> Magistrate's Judgment (720) <input type="checkbox"/> Minor Settlement (730) <input type="checkbox"/> Transcript Judgment (740) <input type="checkbox"/> Lis Pendens (750) <input type="checkbox"/> Transfer of Structured Settlement Payment Rights Application (760) <input type="checkbox"/> Confession of Judgment (770) <input type="checkbox"/> Petition for Workers Compensation Settlement Approval (780) <input type="checkbox"/> Incapacitated Adult Settlement (790) <input type="checkbox"/> Other (799) _____ | <p>Real Property</p> <ul style="list-style-type: none"> <input type="checkbox"/> Claim & Delivery (400) <input type="checkbox"/> Condemnation (410) <input type="checkbox"/> Foreclosure (420) <input type="checkbox"/> Mechanic's Lien (430) <input type="checkbox"/> Partition (440) <input type="checkbox"/> Possession (450) <input type="checkbox"/> Building Code Violation (460) <input type="checkbox"/> Other (499) _____ <p>Appeals</p> <ul style="list-style-type: none"> <input type="checkbox"/> Arbitration (900) <input checked="" type="checkbox"/> Magistrate-Civil (910) <input type="checkbox"/> Magistrate-Criminal (920) <input type="checkbox"/> Municipal (930) <input type="checkbox"/> Probate Court (940) <input type="checkbox"/> SCDOT (950) <input type="checkbox"/> Worker's Comp (960) <input type="checkbox"/> Zoning Board (970) <input type="checkbox"/> Public Service Comm. (990) <input type="checkbox"/> Employment Security Comm (991) <input type="checkbox"/> Other (999) |
|---|---|--|---|

Submitting Party Signature: Magnus E Shreeff Date: 12-9-2020

Note: Frivolous civil proceedings may be subject to sanctions pursuant to SCRCP, Rule 11, and the South Carolina Frivolous Civil Proceedings Sanctions Act, S.C. Code Ann. §15-36-10 et. seq.

FILED
2020 DEC -9 PM 3:11
CLERK OF COURT

STATE OF SOUTH CAROLINA

IN THE COURT OF COMMON PLEAS

COUNTY OF CHARLESTON

2020 -CP-10- 5405

2020 DEC -9 PM 3:11
JULIE J. ARMSTRONG
CLERK OF COURT

FILED

Magnus E Shier
Plaintiff

APPEAL

-VERSUS-

Danny D H
Defendant

Magistrate/Municipal Judge's name:
James A Turner

Magnus E Shier

Plaintiff/Defendant in this civil action make the following claim.

1. I believe that the plaintiff/Defendant resides in Charleston County and is within the jurisdiction of this court.
2. I make this appeal based on the following errors committed by the lower court.

Letters never delivered

Never Served

Customer Owe Me 1926.00

For Services Rendered See Attached Documents

3. I believe, because of the above information, that I am entitled to and request _____

I state under penalty of perjury that the above is correct and truthful

Dated 12-9-2020

Signed Magnus E Shier

Address of plaintiff
332 Cabell

Char SC 29407

509 947 7354

Telephone number

Address of defendant
1954 Dalvey Rd

Char SC 29407

843 364 3700

Telephone number

~~ORIGINAL~~

STATE OF SOUTH CAROLINA)
)
)
COUNTY OF CHARLESTON)
)
)

2020CV1011501116
CIVIL CASE NUMBER

IN THE MAGISTRATE'S COURT

TRANSCRIPT OF JUDGMENT
FIND FOR PLAINTIFF

Names of Parties Against Whom Judgment is Granted	Attorneys
Magnus Shier Dba Edgewater Kitchens 1954 Dulsey Rd. Charleston, SC 29407	

Names of Parties To Whom Judgment is Granted	Attorneys
Danny D Henriksen 322 Cabell St. Charleston, SC 29407	

DAMAGES AND COSTS

Amount of Judgment:	\$6,662.00
Costs:	
Court Costs / Filing Fees	\$296.00
Interest	\$0.00
Attorney Fees	\$0.00
Total Amount of Judgment:	\$6,958.00
Date of Judgment:	11/20/2020

I, James A Turner, Magistrate in and for the County of Charleston, do hereby certify that the foregoing is a correct transcript of the Judgment issued by this Court.

James A Turner
Charleston County Magistrate

November 20, 2020



Judge James Turner
Magistrate

NORTH AREA SMALL CLAIMS COURT

843.202-6650
Fax: 843.202-6652
Lonnie Hamilton, III Public
Services
Building
4045 Bridge View Drive
Post Office Box 70235
North Charleston, SC 29415-0235

November 5, 2020

Danny D. Henriksen
322 Cabell St.
Charleston, SC 29407

Magnus Shier dba
Edgewater Kitchens
1954 Dulsey Rd.
Charleston, SC 29407

**RE: Danny D. Henriksen vs Magnus Shier DBA Edgewater Kitchens
Case No.: 2020CV1011501116**

Notice to All Parties:

Please be advised that a Default Hearing has **been scheduled** for:

Friday, November 20, 2020 AT 10:15 AM

**Please check in at the Small Claims counter prior to entering the
courtroom.**

Sincerely,

Linda West
Summary Court Specialist

Napps

Date 9/10/2020

Small Claims-North

Judge : James A Turner

4045 Bridge View Drive

North Charleston, SC 29405

Not Member

FILED IN
CHARLESTON COUNTY
SEP 09 2020
NORTH AREA
SMALL CLAIMS COURT

Your Honor

I, Danny Henriksen, have filed a claim in small claims court case number 2020CV1011501116, Reference # 1005. The court has tried to serve the defendant Edgewater kitchens, Magnus Shier to no avail. I have hired a private process server Jake Brunson who has tried five times to serve Mr. Shier with no success. I am requesting permission from the court to publish the serving notice in the Newspaper.

If permission is granted please inform me of the required information to be posted in the notice.

Thank you,

Danny D. Henriksen

Danny D Henriksen

322 Cabell St.

Charleston SC 29407

Ph. 5099477354

*Motion
Served
9/13/2020*

~~DHenriksen~~

~~DDHenri70@hotmail.com~~

DDHenri70@hotmail.com

(100 Broad St) (Dana)
843 958 5000

A

True

B

Four to Six week

C

Now its 5 weeks

D

Quality work takes twice as long as Production work

E

Why schedual delivery before you are read

F

The price for extra 2026.00
Materials Labor Refused to pay

G

yet offered to provide labor for free Dan said "I will take care of it"

H

Why schedual delivery before you are ready

I

4" backsplash on top of Counter

J

This was a Contract without a price Estimate was sent via email + Quick books

Answers

- ① Dan said he was going to help me with the job No help after First 2 weeks this is why job took longer than anticipated
- ② The drawing has wall tile for aesthetic purposes the backsplash was installed per Item 9 on Complaint
- ③ This was never discussed period
- ④ Pantry was Completely Finished
- ⑤ Parts & Doors were Ordered and arrived 4/04/20 called to deliver Dan refused delivery several times Island Trim was received 2/15/2020 called to install no answer never told me I would not be allowed to finish This was approximately 500.00 worth of Labor 5 hours work
- ⑥ Dan Refused to pay me the money he agreed to for extras 9 day or after he talked. So I wanted money for Work & Mat.

7 Four to Six weeks with Dan's help

8 Dan said he was doing the backsplash - wall tile himself.

9 Palmetto Surfacing installed the Counter top, & 4" Backsplash
1-23-2020 The glass doors never discussed.

10 Dan was called Home Card board These figures are wrong including the 3,000. w. He agreed to pay me for extras and then decided he was not going to pay. This was the start of the sour taste in my mouth.
Estimate & Install Shoe Extra Drywall Extra Material & Labor 26!

11 There was a fan in the window to create a vacuum & Drop cloth over Door. Dan's Children moved through it when instead of front Door. Chop saw did have a bag on it. Sander had bag. Planer produces large particles

12 Countertop & backsplash installed
Waiting for Forest Danc Son to finish painting

- 12 Told Dan whenever the cabinet was Delivered
- 14 After this most normal people would have left + never come back. I finished all Items on Dams List and soon ass soon as he let me back in house after giving him the key he still changed the locks
- 15 Paying for services when rendered is normal after trust is broken
- 16 Installed Last Cabinet
- 17 " " Base + Trim Last Cabinet
- 18 Waiting for Forest to finish Painting
- 20 Waiting for Island trim to arrive from Manufacture. Don't know anything about Glass Doors No tile on contract
- 21 Never Informed I was not welcome + Come Complete Top. We offered several times to come + Complete Job

22 We offered to give Dan
all the Doors & Trim to finish
Kitchen for Free he refused to
receive the material.

Cabinet Window Door
Never discussed That

26 Tile Mention of tile on
contract

27 Refused Service

28 600-500 Due = 100.00 Maybe

23 Don't Know why no explanation

24 We told him to come pick up
materials to finish

Dan Said he was going to help me with job

Time Line 322 Cabell Kitchen

Father Sick Did not help who needed Did not have contact for

A 08/20/19 Paid \$300.00 for initial consultation and work scope verification. This fee was to be deducted from contract price if awarded.

B 09/26/19 Entered into contract Paid \$19,119.84 was told that kitchen would be complete in four weeks, except for appliances, electrical, and plumbing.

C 12/02/19 Work started, completed tear out in one day. Project to be 4 to 5 weeks.

D 12/27/19 Payment of \$6,657.00 noticed work was going slow.

E 01/07/20 Moved appliance delivery from 01/13/20 to 01/27/20.

F 01/17/20 Without any prior consent, presented an invoice for additional work, for sheetrock work, administrative fee, and floor moldings amount of \$3100.00. I informed him that the work was covered under the original contract.

G 01/20/20 Argument over what was covered under the initial contract. He said the backsplash tile work was not covered under contract.

H 01/22/20 Moved appliance delivery from 01/27/20 to 02/10/20.

I 01/23/20 Counter tops were installed by Palmetto surfacing and sinks were installed they asked if I wanted the four inch counter top backing, I said yes. Magnus said he needed another payment.

J 01/24/20 Paid Magnus \$1733.00, he said he needed more than that, and he wanted to see the contract I was talking about. He followed me to my dad's house on 2222 Longview Court, and showed him the contract which he had signed. I knew at this time I would have to take him to court, Kitchen still progressing very slow and late.

* Agreed to pay next morning

* He would not pay

EDGEWATER KITCHENS COMPLAINT

- 1 Contractor did not complete work on cabinets in a timely manner.
- 2 Did not tile the backsplash per drawings
- 3 Did not install cabinet glass doors on the north wall.
- 4 Did not finish the corner pantry installation.
- 5 Did not finish the Island trim or install cabinet door.
- 6 Contractor did extort payments to install the final cabinet.
- 7 Edgewater kitchens entered into a contract, to complete my kitchen on 9/26/19 with the exceptions of appliances, electrical, and plumbing. The project according to them would take approximately four weeks. They were to install the cabinets, Island, corner pantry, complete the backsplash, install the counter tops per the agreed drawings and artistic designs.

8 During the negotiations of the contract, we discussed in length what was to be done. We discussed the tiling of backsplash with subway tile and the corner pantry. The cabinet glass doors were the last addition to the contract.

9 They had told me were to go to look at designs of tile and countertops. The initial price of the work was 25,500.00. When the backsplash was added the price was 29119.84. The cabinet glass windows on the north wall was, the last item which raised the price to 31,509.84.

10 Into the renovations on the sixth week, problems with working relations started when the contractor presented on 1/17/20 addendum prices for so called additional work, without any prior approval. The figures were wrote on a piece of cardboard, \$1000.00 for administration fees for counter top installation, \$1000.00 for sheetrock work, \$1100.00 for floor molding. I told him that we had discussed that before we entered into the contract and it was included. That is when he wanted to see the contract I was talking about.

11 The Contractor basically held the kitchen unusable for 8 weeks. He used saws, planners, and sanders in the house without catch bags attached. Although it is

sometimes necessary to use these tools inside the house, most of the time it is not. I asked that he not use the saw inside the house unless necessary after the counter tops were installed, he did so anyway. He reduced his hours from 30 per week, to about 20 prolonging the job while continuing to create a mess inside the house and creating a hazardous environment for the occupants of the house. After 8 weeks, on January 30th, my son and I removed his tools from the kitchen and notified him to pick them up.

On February 1st meeting at Edgewater Kitchens office. Paid \$2850 to get last or extortion cabinet installed. On 2/3/20202 he started installing the last cabinet.

Please see attachments

1. Contract signed by Magnus Shier
2. Financial figures for complaint.
3. Time line for contract.
4. Text messages for time of contract.
5. Pictures of kitchen, living room and bedroom during remodeling of kitchen.

- 12 01/28/20 Another argument in the meeting, Magnus wanting more money. No work performed. Palmetto Surfacing came and installed last piece of counter top backing behind stove.
- 13 01/29/20 Worked 2 hours. Called and asked when the last cabinet would be installed he said whenever he got paid.
- 14 01/30/20 Jacob and myself moved all of Magnus tools and equipment out of the house and started cleaning up.
- 15 02/01/20 Meeting at Edgewater kitchens office, told Magnus there would be no more using saw inside the house, and he had one week to finish the job. Paid \$2850 to get last or extortion cabinet installed.
- 16 02/03/20 Installed the extortion cabinet in the afternoon.
- 17 02/04/20 Installed bottom trim on extortion cabinet. Informed me that the trash can pull out drawer would not be shipped until February 28.
- 18 02/05/20 No show
- 19 02/06/20 Installed trim around window and floor molding on closet.
- 20 02/07/20 Met Magnus and Pat O'Neil house told Pat to bring her camera if she wanted to take pictures of their work. Met at 3 PM Paid \$1000. Island trim not finished, door on garbage cabinet not installed, Pantry closet not finished, glass doors on cabinet not installed, and backsplash not tiled.
- 21 04/16/20 Pat O'Neil called and asked if Magnus could come and finish the job. I told her I would have to contact my sons. My sons and I decided it would be better not to let him return to finish work.
- 22 04/22/20 Called Magnus Shier asked if I could have cabinet door to install on the garbage cabinet, he said I still owed him \$500.00 on the contract and I could have the door once I paid him.

Never

Called

We offered to give Him the Door & Trim NO Cash was offered

Not

NO Cash was offered

23 04/29/20

Pat O'Neil called again asking Magnus and I have a meeting. I told her I was not interested in having a meeting.

24 05/15/20

Pat O'Neil called and said I could have the cabinet door. + trim

Financial Figures for Complaint

25	Cabinet window Doors	\$2390
26	Backsplash Tile	\$2272
27	Finish Trim on Island and garbage cab. Door	\$2000
28	Preparation and Filing fees	\$0600
		<hr/>
	Total	\$7262

STATE OF SOUTH CAROLINA)
COUNTY OF CHARLESTON)

2020CV1011501116
CIVIL CASE NUMBER
IN THE MAGISTRATE'S COURT
AFFIDAVIT OF SERVICE

Danny D Henriksen
322 Cabell St.
Charleston, SC 29407
(509) 947-7354

PLAINTIFF(S)

Vs

Magnus Shier Dba Edgewater Kitchens
1956 Dulsey Rd.
Charleston, SC 29407

DEFENDANT(S)

FILED IN
CHARLESTON COUNTY
SEP 21 2020
NORTH AREA
SMALL CLAIMS COURT

PERSONALLY PREPARED BEFORE ME, the undersigned deponent, who being duly sworn
says that (s)he served the _____ in this action
(Describe document(s) served)

on _____ by delivery to
(Name of party served)

_____ personally;
(Name of party served)

_____ the _____ of the party served,
(Name of person served) (Note relationship to party)

and a person of discretion residing at the residence of the party served;

_____ the _____ of _____
(Name of person served) (Title) (Name of corporate party served)

and leaving with (him) (her) a copy at _____
(Street address)

in _____ County, South Carolina,
(City or Town) _____ County

on _____ at _____ o'clock

that deponent knows the person so served, and that deponent is not a party of this action, is not less than eighteen (18) years of age and has no interest therein or connection therewith.

Unable to locate and serve the above process on the defendant after diligent efforts to do so. The process is returned unexecuted.

Sworn to and Subscribed before me
this 23 day of Oct, 2020

[Handwritten Signature]
Signature of Deponent

[Handwritten Signature: Courtney Powell]
Notary Public for South Carolina

My Commission expires 10/30/2029 Entered in the Sheriff's Service Book on _____
Book _____ Page _____ Number _____

Return to:
Small Claims - North
4045 Bridge View Drive
P. O. Box 70235
North Charleston, SC 29405
Phone: (843) 202-6650
Fax: (843) 202-6652

Courtney Powell
Notary Public, State of South Carolina
My Commission Expires 10/30/2029

[Handwritten: 2/18/21 Alex Rieger #D]

Danny D Henriksen
322 Cabell St.
Charleston, SC 29407
(509) 947-7354

PLAINTIFF(S)

Vs

Magnus Shier DbA Edgewater Kitchens
1956 Dulsey Rd.
Charleston, SC 29407

DEFENDANT(S)

FILED IN
CHARLESTON COUNTY
SEP 21 2020
NORTH AREA
SMALL CLAIMS COURT

PERSONALLY PREPARED BEFORE ME, the undersigned deponent, who being duly sworn
says that (s)he served the _____ in this action
(Describe document(s) served)

on _____ by delivery to
(Name of party served)

_____ personally;
(Name of party served)

_____ the _____ of the party served,
(Name of person served) (Note relationship to party)

and a person of discretion residing at the residence of the party served;

_____ the _____ of _____
(Name of person served) (Title) (Name of corporate party served)

and leaving with (him) (her) a copy at _____
(Street address)

in _____ County, South Carolina,
(City or Town) County

on _____ at _____ o'clock

that deponent knows the person so served, and that deponent is not a party of this action, is not less than eighteen (18) years of age and has no interest therein or connection therewith.

Unable to locate and serve the above process on the defendant after diligent efforts to do so. The process is returned unexecuted.

Sworn to and Subscribed before me)
this _____ day of _____, 20____)
) _____
) Signature of Deponent

Notary Public for South Carolina) Entered in the Sheriff's Service Book on _____
My Commission expires _____) Book _____ Page _____ Number _____

Return to:
Small Claims - North
4045 Bridge View Drive
P. O. Box 70235
North Charleston, SC 29405
Phone: (843) 202-6650
Fax: (843) 202-6652

2487 Ash River #D

2020cv0115 01116

Case No:	FILED IN CHARLESTON COUNTY
Filed:	AUG 03 2020
Served:	NORTH AREA SMALL CLAIMS COURT
Default:	
Hearing:	

STATE OF SOUTH CAROLINA
COUNTY OF CHARLESTON

IN THE SMALL CLAIMS COURT

DANNY D. HENRIKSEN
Plaintiff

322 CABELL ST.
Street Address

CHARLESTON S.C. 29407
City State Zip

509 947 7354
Phone

Edgewater Kitchens
Defendant MAGNUS SHIER DBA.

1954 DULSEY RD.
Street Address

CHARLESTON S.C. 29405
City State Zip

843 225 6263
Phone

I, the plaintiff in this civil action, make the following claim against the defendant:

- 1.) I believe that the defendant is a resident of _____.
- 2.) Check a, b, or c to indicate the type of suit and supply documents required.
 - a. () This is a suit on a note; Two (2) copies of note attached. Defendant has defaulted in payment of said note with balance of \$ _____ now due and payable.
 - b. () This is a suit on an account; Two (2) copies of statement attached. Sign as affiant swearing to statement and have your signature notarized.

SWORN and subscribed before me this
_____ day of _____ 20 _____

Attached to this complaint is a statement of account which I swear to be true and correct, with no part of the balance having been paid.

NOTARY PUBLIC, State of South Carolina
My Commission Expires: _____

Affiant=s Signature (Plaintiff)

c. (X) OTHER. This is a claim based on the following facts: (Describe Complaint)

See ATTACHED

(attach supplement if necessary)

3.) I believe because of the following information, that I am entitled to, and request a judgment for

\$ 7262.00 and/or other relief:

(Include any costs resulting from this action. (Example: court costs, legal fees, interest)

I STATE UNDER PENALTY OF PERJURY THAT THE ABOVE IS CORRECT AND TRUTHFUL.

8/3/2020
Date

Danny D. Henrikson
Signature of Plaintiff or Attorney

STATE OF SOUTH CAROLINA)
COUNTY OF CHARLESTON)

2020CV1011501116
CIVIL CASE NUMBER
IN THE MAGISTRATE'S COURT
AFFIDAVIT OF SERVICE

Vacant Lot 7-Aug
26

Danny D Henriksen
322 Cabell St.
Charleston, SC 29407
(509) 947-7354

PLAINTIFF(S)

Vs

Magnus Shier Dba Edgewater Kitchens
1954 Dulsey Rd.
Charleston, SC 29407

1956 Dulsey Rd.

VACANT

DEFENDANT(S)

Up for RONA

PERSONALLY PREPARED BEFORE ME, the undersigned deponent, who being duly sworn

says that (s)he served the _____ in this action
(Describe document(s) served)

on _____ by delivery to
(Name of party served)

_____ personally;
(Name of party served)

_____ the _____ of the party served,
(Name of person served) (Note relationship to party)

and a person of discretion residing at the residence of the party served;

_____ the _____ of _____
(Name of person served) (Title) (Name of corporate party served)

and leaving with (him) (her) a copy at _____
(Street address)

in _____ County, South Carolina,
(City or Town) County

on _____ at _____ o'clock

that deponent knows the person so served, and that deponent is not a party of this action, is not less than eighteen (18) years of age and has no interest therein or connection therewith.

Unable to locate and serve the above process on the defendant after diligent efforts to do so. The process is returned unexecuted.

Sworn to and Subscribed before me)
this _____ day of _____, 20 _____)
Signature of Deponent

Notary Public for South Carolina) Entered in the Sheriff's Service Book on _____
My Commission expires _____) Book _____ Page _____ Number _____

Return to:
Small Claims - North
4045 Bridge View Drive
P. O. Box 70235
North Charleston, SC 29405
Phone: (843) 202-6650
Fax: (843) 202-6652



NORTH AREA SMALL CLAIMS COURT

4045 Bridge View Drive
North Charleston, SC 29405-7476

Return Service Requested

Magnus Shier dba
Edgewater Kitchens
1954 Dulsey Rd.
Charleston, SC 29407



NORTH AREA SMALL CLAIMS COURT

4045 Bridge View Drive
North Charleston, SC 29405-7476

Return Service Requested

Danny D. Henriksen
322 Cabell St.
Charleston, SC 29407

STATE OF SOUTH CAROLINA
COUNTY OF CHARLESTON

Danny D Henriksen
322 Cabell St.
Charleston, SC 29407

FILED IN
CHARLESTON COUNTY
AUG 13 2020
NORTH AREA
SMALL CLAIMS COURT

NOTIFICATION OF NON-SERVICE

RE: Danny D Henriksen

Vs Magnus Shier Dba Edgewater Kitchens

PLAINTIFF(S)

DEFENDANT(S)

CASE NUMBER: 2020CV1011501116

Please be advised that your civil action has been returned from the Charleston County Sheriff's Department/Constable/Process Server with non-service for the following reason(s):

- Defendant does not reside in Charleston County
- Defendant no longer resides at given address
- Defendant is deceased
- Defendant's address is unknown
- Vacant Lot**
- Apartment number or lot number required
- Defendant never home
- Unable to serve after five or more attempts
- Restraining Orders - There is NOT a fee of \$10 to attempt service at a new address.
- Other: _____

1956 Dulsey Rd.

Please note that **the Court must receive any new address within 30 days** from the date of this letter with a fee of \$10 to attempt service at the new address. Should no new address be supplied within the number of days stated above, this action will be dismissed and you will be required to re-file for further action. Please submit any new information to the below address or fax to the number shown.

Small Claims - North
4045 Bridge View Drive
P. O. Box 70235
North Charleston, SC 29405
Phone: (843) 202-6650
Fax: (843) 202-6652
August 13, 2020

was not served or
called. Appointment Sign in
front window at Showroom
9487 Ashley River Rd Unit D
Chas SC 29414

Can find easily on Google
Paper work for Notary Questionable
No Seal

Date written Orev

No Nothing but Address on Other

One Page says 1956 is a Vacant

lot house was built 504 years ago.

Magnus E Shier III

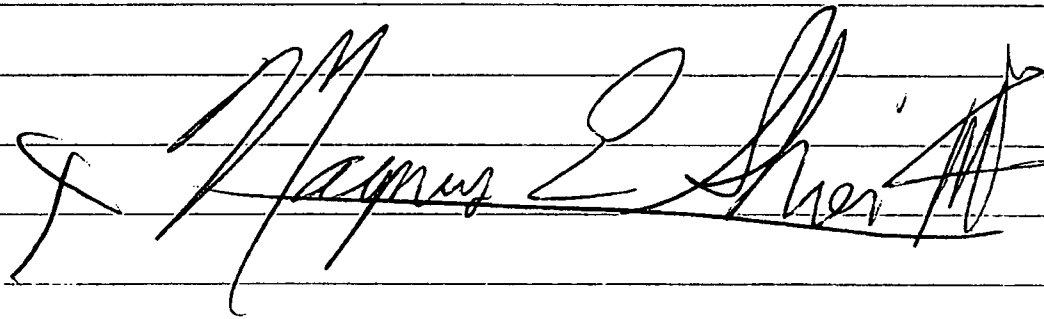
A handwritten signature in cursive script that reads "Magnus E Shier III". The signature is written in black ink and is positioned below the typed name.